

SIMOTICS Low-Voltage Motors

1LE0 Option Line

[siemens.com/drives](https://www.siemens.com/drives)

Ordering
Brochure

Edition
06/2022

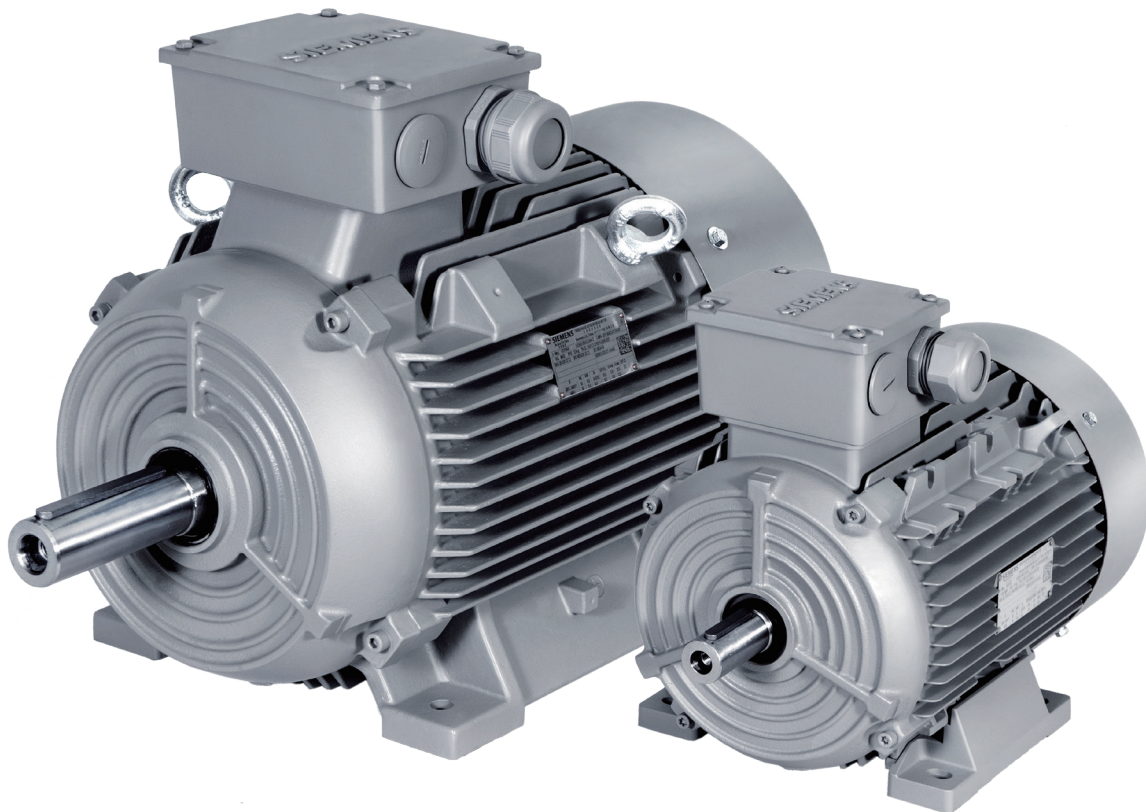

Supersedes:

Ordering Brochure
SIMOTICS Low-Voltage Motors
1LE0 Option Line 05/2022

- SIMOTICS Low-Voltage Motor
1LE0 Option Line 11/2021

- SIMOTICS Low-Voltage Motors
Distribution offering and 1LE0 option line
Ordering Brochure 07.2014

- SIMOTICS GP 1LE0 Low-Voltage Motors
Catalog D 81.5N 09.2011
Article No.: E20001-K0369-C600-X-5D00

Additional information is provided in the following documents and/or links:

- SIMOTICS Low-Voltage Motors
Catalog D 81.1 · 2018
Article No.: E86060-K5581-A111-B2-7600

- Energy saving/Energy-saving program SinaSave
Further information regarding energy savings and
the energy-saving program SinaSave can be found
at the following internet addresses:
www.siemens.com/sinasave
www.siemens.com/energysaving

This brochure is only applicable
in designated countries for the following regions:

- Asia
- Africa
- Middle East
- South America

Content

1	Introduction	
	General overview	2
	Product highlights	4
	Highlight features	5
	SIMOTICS Low-Voltage Motors	6
	Key features	6
	Special features	7
2	Technical features	
	Applicable standards and specifications	8
	Efficiency	10
	Types of construction	11
	IP rating	12
	Thermal class	13
	Rating plates	14
	Derating	15
	Anti-condensation	16
	Motor protection	18
	Converter application	19
	Noise	22
	Bearings	23
	Bearing types	25
	Cantilever forces	26
	Terminal box	28
	Packaging size	29
	Handling and storage	31
	Certificates	31
3	SIMOTICS Option Line	
	Motor selection and article number code	32
	Cast-iron series 400 V – IE1	34
	Cast-iron series 380 V – IE1	37
	Cast-iron series 400 V – IE2	40
	Cast-iron series 380 V – IE2	43
	Cast-iron series 400 V – IE3	46
	Cast-iron series 380 V – IE3	49
	List of options	52
	SIMOTICS 1LE0 – Dimensional drawings	54
	SIMOTICS 1LE0 – Flange dimensions	60

Introduction

General overview

SIMOTICS – The name for the widest range of motors in the world

With 150 years of experience, we have driven motor technology forward, optimized them and played a decisive role in defining them.

Based on over 150 years of experience Siemens offers with SIMOTICS the most comprehensive range of motors for industrial applications proven with more than 40 million Siemens motors and drives installed around the world.

Our low-voltage motors meet the latest efficiency standards and stand for highest quality, reliability and compactness. Our motors are optimally integrated into the drive train. They are perfectly harmonized for the use with SIRIUS motor starters and SINAMICS frequency converters.

Our foundation of outstanding quality is the unparalleled experience from numerous Siemens production facilities around the world and close to our customers. This is how our experience drives your success!

Siemens is present in more than 190 countries around the world and a true local global player. We manufacture locally serving the individual markets. All of our products are based on one common global quality and design standard derived from our German engineering roots adapted to global market requirements.

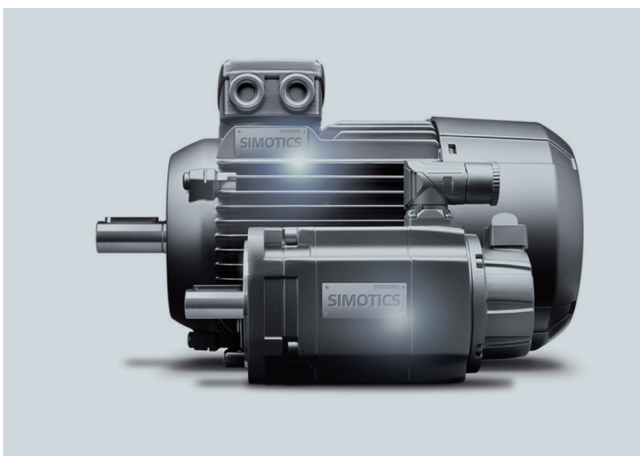

SIMOTICS low-voltage motors

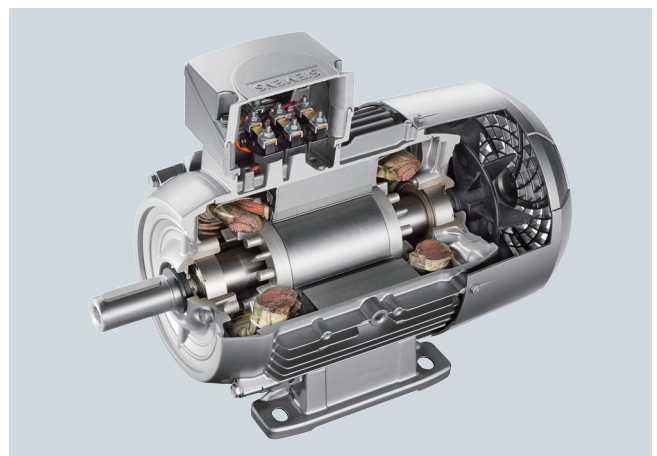

Cut-away aluminum motor

This brochure is using all of our 150 years experience and focuses on our SIMOTICS low-voltage IEC motors, It covers cast-iron motor series for general purpose. Additional offering is always available from our standard motor catalog portfolio. We comply with the latest efficiency standards and describe motors for IE1, IE2 and IE3 efficiencies.



IE1, IE2 & IE3 Cast-iron motors (1LE0)

- Frame size: 80 – 355
- Rated output: 0.55 – 315 kW
- No. of poles: 2, 4 and 6
- Voltage & frequency: Up to 690 V \pm 10%, 50 Hz, 60 Hz
- Type of construction: IM B3 and other types of construction



SIMOTICS 1LE0 Cast-iron motor

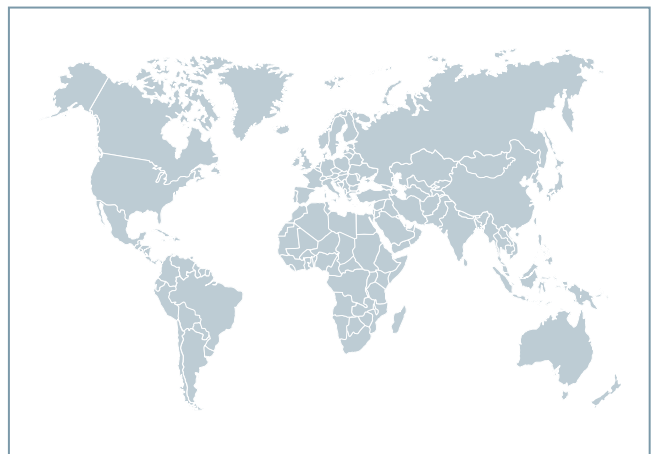

Product highlights

1. **Wide range of options** – can be selected according to specific customer requirements.
2. **Fulfill voltage and construction requirements** – 1LE0 Option Line offers various rated voltages and mounting types.
3. **Easy retrofit and upgrade to higher efficiency class** – due to harmonized design dimensions throughout the whole 1LE0 motor family.
4. **Common user and spare parts** – are applicable within the 1LE0 motor line.
5. **Increase plant and system availability** – Options of winding protection, insulated bearing and separately driven fan enhance the availability and thus reliability of the system.
6. **Rotatable terminal box**
7. **Global support** – worldwide warranty and service

Application note

- **Pump:** Energy saving for quadratic torque load with variable speed operation
- **Fan:** Ideal for flow control application
- **Material handling:** Effectively working with continuous and intermittent periodic duties. Reliable operation.



Pump

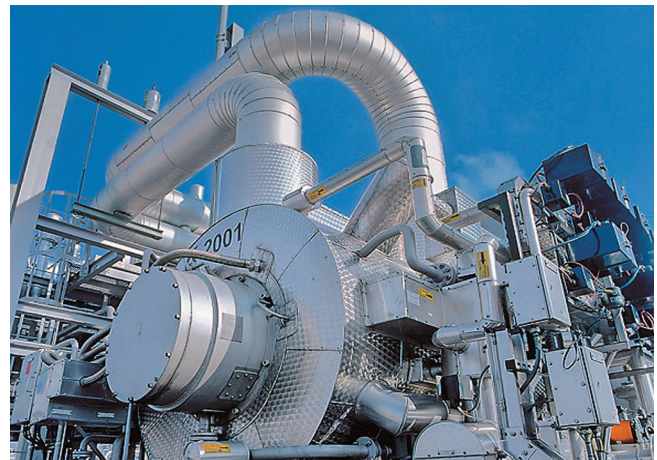

Fan



Material handling

Highlight features

Flexible control options

With separately driven fan the motor can be worked with inverter in constant torque operation. This is the result of continuous full speed ventilation of forced fan option.

Working with SINAMICS, you can rely on a drive family with flexible control options – with V/f control as well as vector control. As a result, applications can be addressed with basic speed control and with higher speed precision with encoderless vector control or with encoder.

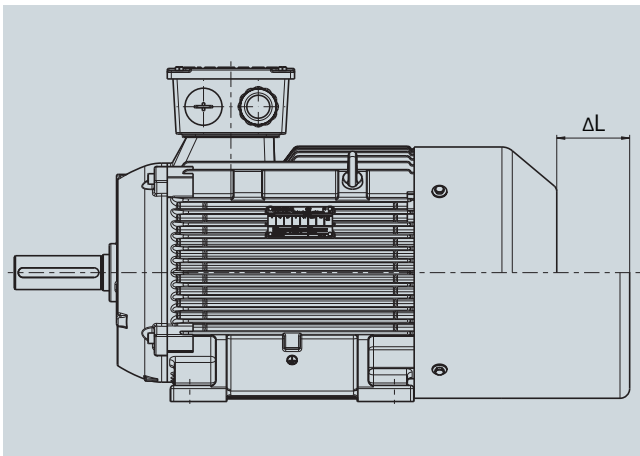
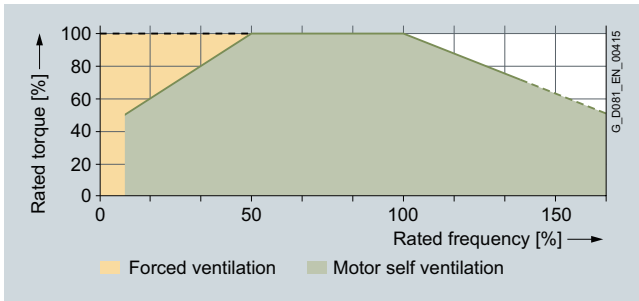

Motor with separately driven fan

Highlight motor options

- **Insulated bearing, encoder and separately driven fan** to increase reliability for converter operation
- **PT1000 and Pt100 sensors** are additional protections that can evaluate motor temperature for alarm and tripping.
- **Measuring nipple** for SPM shock pulse measurement for bearing inspection
- **Vibration severity level B** according to IEC 60034-14
- **Rotation of terminal box** on right or left hand side of the motor drive end

Technical data for separately fan

Motor frame size	Voltage (V)	Frequency (Hz)	Rated output (W)	Current (A)	Speed (r/min)	ΔL (mm)
80	220 Δ /380Y	50	30	0.14/0.08	2800	55
90	220 Δ /380Y	50	30	0.14/0.08	2800	65
100	220 Δ /380Y	50	52	0.21/0.12	2800	80
112	220 Δ /380Y	50	52	0.21/0.12	2800	90
132	220 Δ /380Y	50	45	0.35/0.2	1400	75
160	220 Δ /380Y	50	45	0.35/0.2	1400	55
180	220 Δ /380Y	50	120	1.04/0.6	1400	65
200	220 Δ /380Y	50	120	1.04/0.6	1400	65
225	220 Δ /380Y	50	120	1.04/0.6	1400	60
250	220 Δ /380Y	50	230	1.73/1.0	1400	80
280	220 Δ /380Y	50	230	1.73/1.0	1400	110
315	220 Δ /380Y	50	370	1.91/1.1	1250	90
355	220 Δ /380Y	50	550	2.18/1.26	1350	100

Note: The fan can be running with supply 210 ~ 240 VD/360 ~ 420 VY 50 Hz, and also 220 ~ 260 VD/380 ~ 480 VY 60 Hz. Other voltage supply, possible on request.

SIMOTICS Low-Voltage Motors – Key features

The low-voltage motor unique key features:

1. Low vibration

The low vibration results from our precision manufacturing and the use of defined and controlled quality components. The quality bearings used augment this and result in longer life and lower noise. See chapter 2 – Technical features.

2. IP55 as standard

Our IP55 design covers a vast majority of applications and is tested and proven for full lifetime, plus you have the full modification possibility within IP55 rating.

3. F to B thermal class for built-in reserve

The Siemens motors are rated at normal sinusoidal voltage with a class B (130 °C) temperature rise. The windings are rated to class F (155 °C) thus allowing for reserve for the additional losses associated with variable speed drive operation and / or higher ambient temperature and / or overload conditions when operating directly on-line. F to F is possible for converter operation.

4. Converter operation for variable speed as standard

For all motors offered up to 460 V converter operation is possible as standard configuration – no special option or series is needed. Insulation bearing option code available for FS 250 and above.

5. Embedded thermal protection 3 × PTC

Thermal protection with PTC thermistors with 3 embedded temperature sensors for tripping is provided as option.

6. Global motor platform

Our motor design is based on one global motor platform with the same look and feel on all low-voltage motor IEC products.

For details on the above mentioned key features, please see chapter 2 "Technical features".

SIMOTICS Low-Voltage Motors – Special features

		SIMOTICS General Purpose		
		Cast-iron series		
Efficiency class		IE1	IE2	IE3
Series		1LE0022	1LE0021	1LE0023
DOL	Voltage up to	690 V	690 V	690 V
	Frequency	50 Hz / 60 Hz +3% / -5%	50 Hz / 60 Hz +3% / -5%	50 Hz / 60 Hz +3% / -5%
Converter operation up to		460 V _{rms}	460 V _{rms}	460 V _{rms}
Frame sizes		80 ... 355	80 ... 355	80 ... 355
Type of construction	Standard	IM B3	IM B3	IM B3
	Optional	IM B35, IM B5, IM V1, IM B14	IM B35, IM B5, IM V1, IM B14	IM B35, IM B5, IM V1, IM B14
Bearing designation		refer to page 27	refer to page 27	refer to page 27
Others	Metal fan cover	<input type="checkbox"/>	<input type="checkbox"/>	<input type="checkbox"/>
	Metal rating plate	<input type="checkbox"/>	<input type="checkbox"/>	<input type="checkbox"/>
	Drain hole	<input checked="" type="checkbox"/>	<input checked="" type="checkbox"/>	<input checked="" type="checkbox"/>
	Center hole at non-drive end prepared for auxiliary mountings	<input checked="" type="checkbox"/>	<input checked="" type="checkbox"/>	<input checked="" type="checkbox"/>
	Space heater	<input checked="" type="checkbox"/>	<input checked="" type="checkbox"/>	<input checked="" type="checkbox"/>
	Motor protection 3 × PTC	<input checked="" type="checkbox"/>	<input checked="" type="checkbox"/>	<input checked="" type="checkbox"/>
Certificate	CE marking	-	-	<input type="checkbox"/> Only for 50Hz motors
	Routine test	<input checked="" type="checkbox"/>	<input checked="" type="checkbox"/>	<input checked="" type="checkbox"/>
Standard color	Stone gray (RAL 7030)	<input type="checkbox"/>	<input type="checkbox"/>	<input type="checkbox"/>

- = Standard
- = Option
- = Not available

For converter operation with the powers specified in the ordering brochure, the motors are used according to temperature class 155 (F), i.e. in this case neither a service factor > 1 nor an increased coolant temperature is possible.

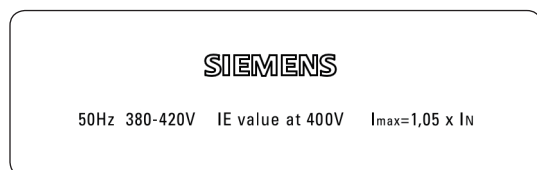

Example of Voltage Sticker (Option code B07)



TIP All our motors are shown as 400 V as the nominal standard. The IEC 60034 regulations state that the rating plate data is only valid at the specific given voltage. In practice, all listed 400 V motors may be used at connection voltages 400 V ±5%. The motors will function well, although there would be deviations from the nominal electrical rating plate data. All 1LE0 motors will have a sticker in addition on the cowl as option (Option code B07) giving the nominal connection voltage as 400 V ±5%. According to the standard, motors can also be operated at 400 V ±10% (Category B), longer operation is not recommended.

Technical features

Applicable standards and specifications

Title	IEC
Efficiency classes and efficiencies	IEC 60034-30-1:30-2014
Rotating electrical machines – Part 1: Rating and performance	IEC 60034-1
Rotating electrical machines – Part 2-1: Standard methods for determining losses and efficiency from tests (excluding machines for traction vehicles)	IEC 60034-2
Rotating electrical machines – Part 5: Degrees of protection provided by the integral design of rotating electrical machines (IP code) – Classification	IEC 60034-5
Rotating electrical machines – Part 6: Methods of cooling (IC Code)	IEC 60034-6
Rotating electrical machines – Part 7: Classification of types of construction, mounting arrangements and terminal box position (IM Code)	IEC 60034-7
Rotating electrical machines – Part 8: Terminal markings and direction of rotation	IEC 60034-8
Rotating electrical machines – Part 9: Noise limits	IEC 60034-9
Rotating electrical machines – Part 14: Mechanical vibration of certain machines with shaft heights 56 mm and higher – Measurement, evaluation and limits of vibration severity	IEC 60034-14
Rotating electrical machines – Part 1: Frame numbers 56 to 400 and flange numbers 55 to 1080	IEC 60072-1
Classification of environmental conditions Part 2-1: Environmental conditions appearing in nature – Temperature and humidity	IEC 60721-2-1
Standard voltages	IEC 60038
Electrical insulation – Thermal classification	IEC 60085

IEC 60034-1 differentiates between Category A (combination of voltage deviation $\pm 5\%$ and frequency deviation $\pm 2\%$) and Category B (combination of voltage deviation $\pm 10\%$ and frequency deviation $+3\% / -5\%$) for voltage and frequency fluctuations.

The motors can supply their rated torque in both Category A and B. In Category A, the temperature rise is approximately 10 K higher than during normal operation.

Standard 60034-1	Category A	Category B
Voltage deviation	±5%	±10%
Frequency deviation	±2%	3% / -5%
Rating plate data stamped with rated voltage a (e.g. 230 V)	a ±5% (e.g. 230 V ±5%)	a ±10% (e.g. 230 V ±10%)
Rating plate data stamped with rated voltage ranges b to c (e.g. 220 V to 240 V)	b -5% to c +5% (e.g. 220 V -5% to 240 V +5%)	b -10% to c +10% (e.g. 220 V -10% to 240 V +10%)

In Category B, the standard does not recommend extended operation, so it is not permissible for explosion-proof motors. See "Rating plate and extra rating plates" for details of the rating plate inscriptions and corresponding examples. The selection and ordering data state the rated current at 400 V. The IEC 60038 standard specifies a tolerance of ±10% for line voltages of 230 V, 400 V and 690 V. Rotors are dynamically balanced with half key. This corresponds to vibration quantity level A.

Tolerance for electrical data

- Efficiency η at
 - $P_{\text{rated}} \leq 150 \text{ kW}$: $-0.15 \times (1 - \eta)$
 - $P_{\text{rated}} > 150 \text{ kW}$: $-0.10 \times (1 - \eta)$
 - With h being a decimal number
- Power factor $-(1 - \cos \phi) / 6$
 - Minimum absolute value: 0.02
 - Maximum absolute value: 0.07
- Slip ±20% (for motors < 1 kW ±30% is admissible)
- Locked-rotor current +20%
- Locked-rotor torque -15% to +25%
- Breakdown torque -10%
- Moment of inertia ±10%

Vibration

Vibration Grade	Frame size (mm)	56 ≤ FS ≤ 132		H>132	
	Mounting	Vibration displacement/ (μm)	Vibration velocity/ (mm/s)	Vibration displacement/ (μm)	Vibration velocity/ (mm/s)
A	Free suspension	45	2.8	45	2.8
	Rigid mounting	-	-	37	2.3 2.8 ¹⁾
B	Free suspension	18	1.1	29	1.8
	Rigid mounting	-	-	24	1.5 1.8 ¹⁾

Note:

¹⁾ The level are vibration velocity limit when the twice line frequency vibration level is dominant defined by IEC 60034-14, for 2p motors that frame size bigger than 132mm.

Efficiency

Standardization of the efficiency classes

Different energy efficiency standards exist worldwide for induction motors: To promote international standardization, the international standard IEC 60034-30-1-1 03/2014 (Rotating electrical machines – Part 30-1: Efficiency classes of single-speed, three-phase, cage-induction motors (IE code) was created. This groups low-voltage asynchronous motors into new efficiency classes.

Applicability (excerpt)

The efficiency classes are grouped according to the following nomenclature (IE = International Efficiency):

- Low-voltage motors up to 1000 V (50/60 Hz with line operation)
- Rating: 0.12 to 1000 kW; with 2, 4, 6, or 8 poles
- Operating mode: S1

The efficiencies in IEC 60034-30-1 are based on the method for determining losses according to IEC 60034-2-1:2014.

Standardization of the efficiency classes

The efficiency classes are grouped according to the following nomenclature (IE = International Efficiency):

- IE1 (Standard Efficiency)
- IE2 (High Efficiency)
- IE3 (Premium Efficiency)
- IE4 (Super Premium Efficiency)

IEC 60034-30-1	NEMA MG1	GB 18613-2020
IE4 ¹⁾		Grade 2(IE4)
IE3	Premium Efficient (60 Hz)	Grade 3(IE3)
IE2	Energy Efficient (60 Hz)	

¹⁾ Defined in IEC/TS 60034-31.

Comparison of IE efficiency classes

Note:

All efficiency classes are stated with reference to 50 Hz data (unless specified otherwise).



TIP

We comply with the latest efficiency standards and describe motors from IE1 to IE3 efficiencies.

Measuring method according to IEC 60034-2-1:2014 for determining the efficiency

With this measuring method, motor losses are no longer applied as a percentage, but are determined by standard methods. The nominal efficiencies are therefore reduced from EFF1 to IE2 and from EFF2 to IE1, even though there have been no technical or physical changes to the motors.

Previously: $P_{LL} = 0.5\%$ of P_1 (consumed power; IEC 60034-2)

Now: P_{LL} = individual measurement (IEC 60034-1)

P_{LL} = load-dependent supplementary losses

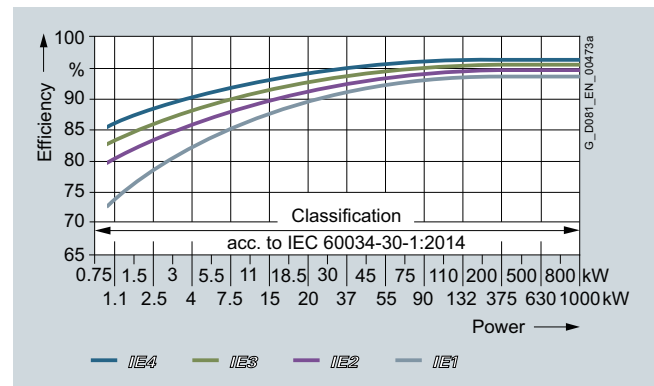

IE1-IE4 efficiencies, 4-pole, 50 Hz, according to power

Types of construction

Construction and mounting type

Construction type	With feet and without flange on the end-shield (DE)					
Mounting type	IM B3 FS 80 ~ 355	IM B6 FS 80 ~ 315	IM B7 FS80 ~ 315	IM B8 FS 80 ~ 315	IM V5 ^{1) 3)} FS 80 ~ 315	IM V6 ²⁾³⁾ FS 80 ~ 315
Diagram						
Letter, position 14 th of Motor code	A	T	U	V	C	D

Construction type	Without feet and with flange on the end-shield (DE)			With feet and with flange on the end-shield (DE)		
Mounting type	IM B5 FS 80 ~ 315S	IM V1 ¹⁾³⁾ FS 80 ~ 355	IM V3 ²⁾³⁾ FS 80 ~ 315S	IM B35 FS 80 ~ 355	IM V15 ¹⁾³⁾ FS 80 ~ 315S	IM V35 ²⁾³⁾ FS 80 ~ 315S
Diagram						
Letter, position 14 th of Motor code	F	G	H	J	W	Y

Construction type	Without feet and with C-flange on the end-shield (DE)			With feet and with C-flange on the end-shield (DE)
Mounting type	IM B14 FS 80 ~ 160	IM V18 ¹⁾³⁾ FS 80 ~ 160	IM V19 ²⁾³⁾ FS 80 ~ 160	IM B34 FS 80 ~ 160
Diagram				
Letter, position 14 th of Motor code	K	M	L	N

¹⁾ At outdoor application, the using of protective cover (Option code H00) is recommended;

²⁾ At out door application the protection of shaft again jet-water is recommended;

³⁾ If vertical mounting with separate fan, please consult with Siemens refer to actual operation conditions on site.

Cooling and ventilation

The 1LE0 standard motors are fitted with an radial flow fan for cooling in accordance with IEC 60034-6 cooling method.

For some special application, separately driven fan should be considered to be configurated.

- The use of a separately driven fan is recommended to increase motor utilization at low speed;
- When motor speed significantly higher than the synchronous speed, the separately fan is also recommended to be used. It can help reduce the motor noise.

The separately driven fan can be supplied already fitted, Option code F70. When the separately driven fan is mounted, the length of the motor increase by ΔL .

IP rating

The IP code (or Ingress Protection Rating, sometimes also interpreted as International Protection Rating) consists of the letters IP followed by two digits or one digit and one letter and an optional letter. As defined in international standard IEC60034-5, IP code classifies and rates the degrees of protection provided against the intrusion of solid objects, dust, accidental contact, and water in mechanical casings and with electrical enclosures.

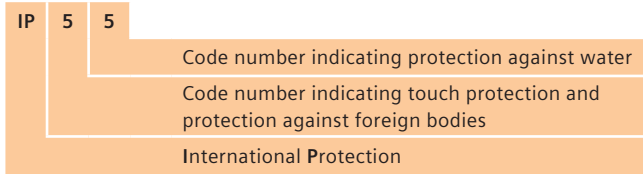

TIP

Some manufacturers offer sealing and protection above IP55. Although it is available as an option, Siemens prefers IP55 as a default standard.

- IP55 covers the vast majority of applications as it offers dust and rain protection
- The IP55 is stable over the life of the motor. Higher protections can need maintenance or an exact assembly to ensure that the higher protection is real and not just on paper.
- Modifications can be made on an IP55 motor whilst maintaining that degree of protection.

Solids, first digit

The first digit indicates the level of protection that the enclosure provides against access to hazardous parts (e.g., electrical conductors, moving parts) and the ingress of solid foreign objects.

Level	Object size protected against	Effective against
0	–	No protection against contact and ingress of objects
1	> 50 mm	Any large surface of the body, such as the back of a hand, but no protection against deliberate contact with a body part
2	> 12.5 mm	Fingers or similar objects
3	> 2.5 mm	Tools, thick wires, etc.
4	> 1 mm	Most wires, screws, etc.
5	Dust protected	Ingress of dust is not entirely prevented, but it must not enter in sufficient quantity to interfere with the satisfactory operation of the equipment; complete protection against contact
6	Dust tight	No ingress of dust; complete protection against contact

TIP

A suitable degree of protection should be selected depending on the operating and environmental conditions. Siemens offers a standard which is most suitable and applicable over the lifetime of a motor such as true IP55 standard.

Liquids, second digit

Protection of the equipment inside the enclosure against harmful ingress of water.

Level	Protected against	Testing for	Details
0	Not protected	–	–
1	Dripping water	Dripping water (vertically falling drops) shall have no harmful effect.	Test duration: 10 minutes Water equivalent to 1 mm rainfall per minute
2	Dripping water when tilted up to 15°	Vertically dripping water shall have no harmful effect when the enclosure is tilted at an angle up to 15° from its normal position.	Test duration: 10 minutes Water equivalent to 3 mm rainfall per minute
3	Spraying water	Water falling as a spray at any angle up to 60° from the vertical shall have no harmful effect.	Test duration: 5 minutes Water volume: 0.7 liters per minute Pressure: 80–100 kN/m ²
4	Splashing water	Water splashing against the enclosure from any direction shall have no harmful effect.	Test duration: 5 minutes Water volume: 10 liters per minute Pressure: 80–100 kN/m ²
5	Water jets	Water projected by a nozzle (6.3 mm) against enclosure from any direction shall have no harmful effects.	Test duration: at least 3 minutes Water volume: 12.5 liters per minute Pressure: 30 kN/m ² at distance of 3 m
6	Powerful water jets	Water projected in powerful jets (12.5 mm nozzle) against the enclosure from any direction shall have no harmful effects.	Test duration: at least 3 minutes Water volume: 100 liters per minute Pressure: 100 kN/m ² at distance of 3 m
7	Immersion up to 1 m	Ingress of water in harmful quantity shall not be possible when the enclosure is immersed in water under defined conditions of pressure and time (up to 1 m of submersion).	Test duration: 30 minutes Immersion at depth of 1 m
8	Immersion beyond 1 m	The equipment is suitable for continuous immersion in water under conditions which shall be specified by the manufacturer. Normally, this will mean that the equipment is hermetically sealed. However, with certain types of equipment, it can mean that water can enter but only in such a manner that it produces no harmful effects.	Test duration: continuous immersion in water Depth specified by manufacturer

Thermal class

The Siemens motors are rated at normal sinusoidal voltage with a class B (130 °C) temperature rise. The windings are rated to class F (155 °C) thus allowing for reserve for the additional losses associated with variable speed drive operation and/or higher ambient temperature and/or overload conditions.

The temperature rise of the winding of the motor is important. It provides a great insight into the design of the motor and its life expectancy. Siemens builds motors to a minimum of class F (155 °C) on all material – continuous operation for a very long life expectancy.

- Class B (130 °C) is the normal utilization – even better.
- Class H (180 °C) is reserved for special application motors.
- Class H motors are considered detrimental for normal use due to the degradation of the overall life expectancy of paint and bearings.
- At class H the outside surface temperature can exceed an unsafe 100 °C.

Siemens uses DURIGNIT insulation materials and capable varnishes – we consider all components including electrical connections and bearing grease – our motors are class F under all circumstances – with reserve built in on top.

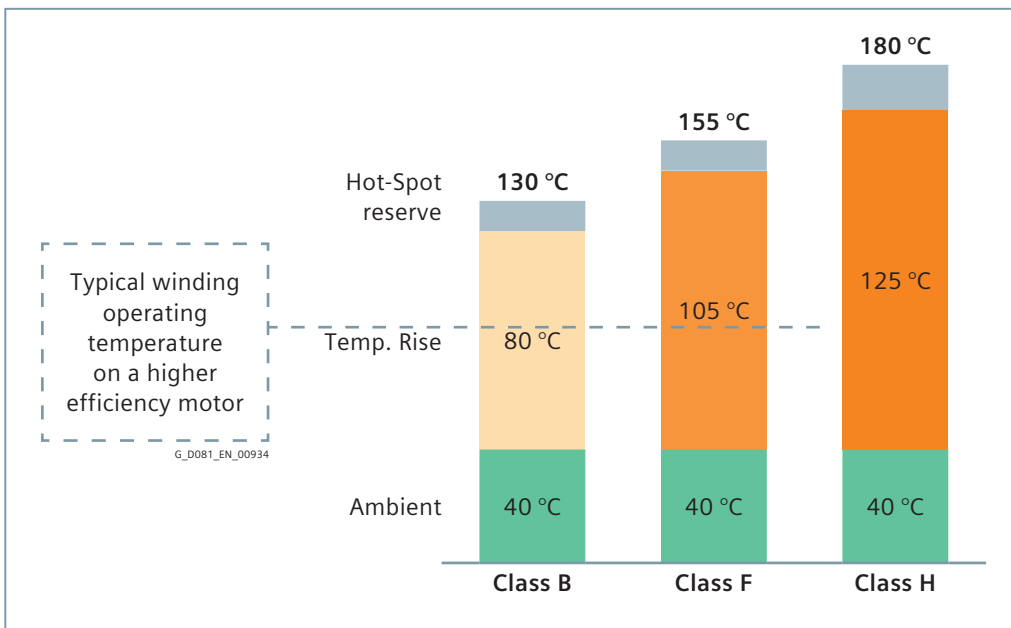

TIP

Siemens builds motors with reserve: The motors are capable to operate at least at 155 °C (class F) but we only rate at a nominal 130 °C (class B). For inverter operation, the temperature class is 105K(class F)

Rating plates

1LE0 series

SIEMENS THREE-PHASE ASYNCHRONOUS MOTOR ^(H)										
Made in P.R.China Siemens Standard Motors Ltd.										
3~Mot. 1LE0021-2AB4			3-4AA4		LMH- 2108 / 800003888993 / 001					
200L IMB3 IP55			235 kg		Th.Cl.155(F)					
BRG DE 6212 2Z C3			BRG NDE 6212 2Z C3		IEC60034					
AMB 40°C										
V	Hz	kW	A	EFF.(%)	cos ϕ	r/min	EFF.Cl.			
400V Δ /690VY 460V Δ	50 60	30 33.5	56/32.5 54	90.7 92.4	0.85 0.85	1470 1765	IE1 IE1			
6	7	8	9	11	10	12	20			

Legend:

- | | |
|---------------------------------|-----------------------------|
| 1 Three-phase low-voltage motor | 11 Efficiency |
| 2 Article No. | 12 Rated speed |
| 3 Serial number | 13 Machine weight [kg] |
| 4 Type of construction | 14 Standards |
| 5 Degree of protection | 15 Temperature class |
| 6 Rated voltage | 16 Frame size |
| 7 Frequency [Hz] | 17 Ambient temperature |
| 8 Rated output [kW] | 18 Bearing at drive end |
| 9 Rated current [A] | 19 Bearing at non-drive end |
| 10 Power factor [cos Φ] | 20 Efficiency class |
| | 21 Balance method |

SIEMENS THREE-PHASE ASYNCHRONOUS MOTOR ^(H)										
Made in P.R.China Siemens Standard Motors Ltd.										
3~Mot. 1LE0021-2DB0			3-4AA4		LMH-					
280S IMB3 IP55			555 kg		Th.Cl.155(F)					
BRG DE 6317 C3			BRG NDE 6317 C3		IEC60034					
Grease: Unirex N3										
Re-grease interval :5000h										
Quantity: 30g										
V	Hz	kW	A	EFF.(%)	cos ϕ	r/min	EFF.Cl.			
400V Δ /690VY 460V Δ	50 60	75 84	132/77 128	94.0 94.5	0.87 0.87	1485 1780	IE2 IE1			

SIEMENS THREE-PHASE ASYNCHRONOUS MOTOR ^(H)										
Made in P.R.China Siemens Standard Motors Ltd.										
3~Mot. 0CV3280B			1LE0023-2DB03-4AA4		LMH-					
280S IMB3 IP55			595 kg		Th.Cl.155(F)					
BRG DE 6317 C3			BRG NDE 6317 C3		IEC60034					
Grease: Unirex N3										
Re-grease interval :5000h										
Quantity: 30g										
V	Hz	kW	A	EFF.(%)	cos ϕ	r/min	EFF.Cl.			
400V Δ /690VY	50	75	133/77	95.0	0.86	1485	IE3			

SIEMENS THREE-PHASE ASYNCHRONOUS MOTOR ^(H)										
Made in P.R.China Siemens Standard Motors Ltd.										
3~Mot. 1LE0022-2DB0			3-4AA4		LMH-					
280S IMB3 IP55			540 kg		Th.Cl.155(F)					
BRG DE 6317 C3			BRG NDE 6317 C3		IEC60034					
Grease: Unirex N3										
Re-grease interval :5000h										
Quantity: 30g										
V	Hz	kW	A	EFF.(%)	cos ϕ	r/min	EFF.Cl.			
400V Δ /690VY 460V Δ	50 60	75 84	133/77 129	92.7 93.2	0.88 0.88	1480 1775	IE1 IE1			

Derating

Environmental

- Degree of motor protection IP55 (IEC 60034-5).
- Altitude shall not exceed 1000 m above sea level (IEC 60034-1).
- Allowed air temperature between –20 and 40 °C (IEC 60034-1).
- Permitted relative humidity:
 - –20 °C < T < 20 °C: 100%
 - 20 °C < T < 30 °C: 95%
 - 30 °C < T < 40 °C: 55%

For higher coolant temperatures and / or site altitudes higher than 1000 m above sea level, the specified motor must be reduced by using the factor k_{HT} . This results in an admissible output (P_{adm}) of the motor:

$$P_{adm} = P_{rated} \cdot k_{HT}$$

Reduction factor k_{HT} for different site altitudes and / or coolant temperature

Site altitude above sea level m	Ambient temperature/coolant temperature					
	< 30 °C	30 ~ 40 °C	45 °C	50 °C	55 °C	60 °C
1000	1.07	1.00	0.96	0.92	0.87	0.82
1500	1.04	0.97	0.93	0.89	0.84	0.79
2000	1.00	0.94	0.90	0.86	0.82	0.77
2500	0.96	0.90	0.86	0.83	0.78	0.74
3000	0.92	0.86	0.82	0.79	0.75	0.70
3500	0.88	0.82	0.79	0.75	0.71	0.67
4000	0.82	0.77	0.74	0.71	0.67	0.63

Note:

If operating conditions exceed above values, please contact our local sales office for the selection of catalog motors.

Anti-condensation

Moisture is present in the air around us. Under the correct circumstances it can condensate. The warmer the air the higher the possible moisture content. As air cools the moisture carrying content reduces to the point when the moisture condenses – called the “dew point”.

This condition can be met several times a day under normal operation, as a motor operates and cools at differing times of the day.

Smaller motors are less susceptible than larger motors due to the smaller volume of moist air possible in the motor. Dew moisture condenses and accumulates in a motor, which is seen as water collection. The water accumulates at the lowest point of the motor. It often does no harm as long as the collection point is below the level of the electrical system.

Two points that need to be paid attention to are, first, how much water there is in the air and when it will condensate. The second is, whether it will do any harm.

Relative humidity	Temperature							
	20 °C	30 °C	40 °C	50 °C	60 °C	70 °C	80 °C	90 °C
10%	2	3	5	8	13	20	29	42
15%	3	5	8	12	19	30	44	63
20%	3	6	10	17	26	39	58	84
25%	4	8	13	21	32	49	73	105
30%	5	9	15	25	39	59	87	126
35%	6	11	18	29	45	69	102	146
40%	7	12	20	33	52	79	116	167
45%	8	14	23	37	58	89	131	188
50%	9	15	26	41	65	98	145	209
55%	10	17	28	46	71	108	160	230
60%	10	19	31	50	78	118	174	251
65%	11	20	33	54	84	128	189	272
70%	12	21	36	58	91	138	203	293
75%	13	23	38	62	97	148	218	314
80%	14	24	41	66	104	157	233	335
85%	15	26	43	70	110	167	247	356
90%	16	27	46	74	117	177	262	377
95%	16	29	49	79	123	187	276	398
100%	17	30	51	83	130	197	291	419

If operating conditions exceed temperatures of 60 °C, please contact our local sales office for the selection of catalog motors.

The table shows the weight of moisture contained in the air, given as g/m³.

The local temperature is on the X-axis and the local relative humidity is shown on the Y-axis.

Blue fields show normal conditions.

Yellow fields show higher moisture – for motors FS ≥ 112 a drain hole is recommended.

For orange colored fields a drain hole is recommended and for more important motors a heating is also recommended (separate space heater or winding heating).



TIP

In humid climates, during motor cool down the air inside contracts, pulling in fresh, warm, humid air. This humidity condensates inside the motor, forming water droplets. Those water droplets have to drain.

Anti-condensation heating can be provided for motors where there is a danger that moisture condensation will form on the winding due to the climatic situation. This anti-condensation heater warms up the air in the motor to a temperature above the dew point temperature in order to prevent condensation forming inside the motor. The anti-condensation heating must not be switched on while the motor is operating.

The graphic shows the temperature at which the moisture in the air will condensate to water. The lines on the right show the local temperature. The X-axis gives the local relative humidity. The "dew point" temperature can be read on the Y-axis.

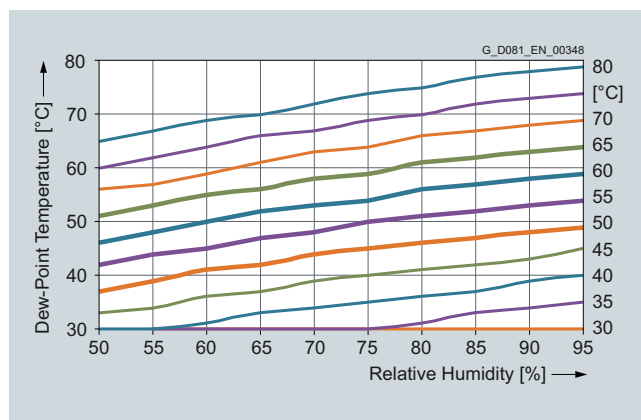

TIP 

Another possible solution is to connect a voltage to the stator terminals U1 and V1 that should be between 4 and 10% of the rated motor voltage. Approximately 20 to 30% of the rated current is sufficient in order to achieve an adequate temperature rise to avoid condensation.

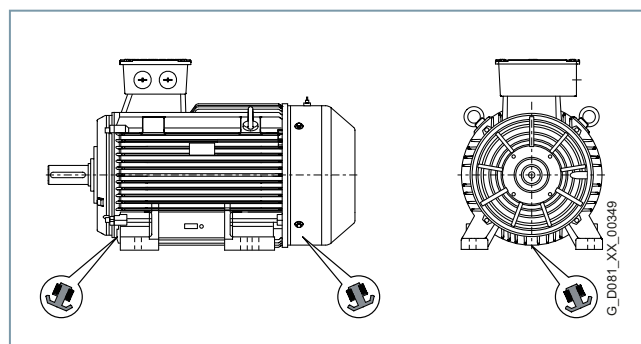

Drain hole location

Frame Size	Q04		Q02	
	Voltage (V)	Power (W)	Voltage (V)	Power (W)
80~90	220	20	230	20
100~112	220	30	230	30
132~160	220	40	230	40
180~200	220	50	230	50
225~280	220	60	230	60
315	220	80	230	80
355	220	100	230	110

Motor protection

PTC thermistor temperature sensors are predominantly used for thermistor motor protection devices (alarm or shutdown) for motors. These thermistors are generally integrated in the winding overhang. As a consequence, the stator winding is directly protected. The temperature difference between alarm and shutdown (trip) is 10 K.

When a limit temperature is reached (nominal tripping temperature), the resistance of PTC thermistors will have a step change. This is evaluated by a tripping unit and can be used to open auxiliary circuits.

Thermal protection with PTC thermistors with 3 embedded temperature sensors for tripping is provided as option. Connection can be done through 2 auxiliary terminals in the terminal box.

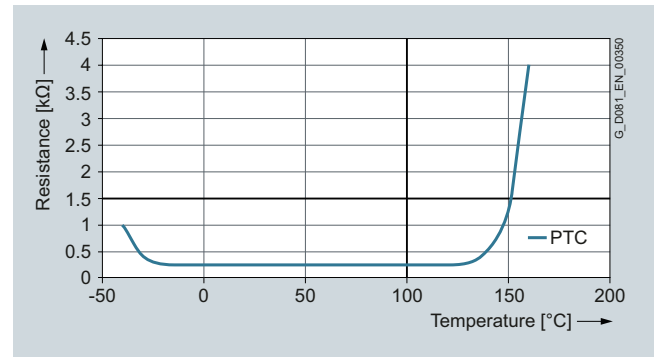

Note:

The PTC thermistors themselves cannot be subjected to high currents and voltages. This would result in destruction of the semiconductor. The switching hysteresis of the PTC thermistor and tripping unit is low, which supports fast restarting of the drive. Motors with this type of protection are recommended for heavy duty starting, switching duty, extreme changes in load, high ambient temperatures or fluctuating supply systems.

Converter application

The insulation system of our motors is capable for converter operation as standard.

For sinusoidal (mains) supplies 690 V_{rms} 50 Hz with:

- phase to phase 1200 V_{rms} capability
- phase to ground 900 V_{rms} capability

For converter operation, as standard:

- 460 V_{rms} max. frequency limited by motor maximum speed 5000 V/m/s

Converter application

Our motors are suitable for pumps, fans, compressors, textile machines and mechanical machine applications where variable or constant speed is required.

In applications where the motor is driven by a converter, the degree of electrical interference depends on the type of converter used (type, number of IGBTs, interference suppression measures, and manufacturer), cabling, distance and application requirements. The installation guidelines of the converter manufacturer with regards to electromagnetic compatibility must be considered at all times during the design and implementation phases.

At rated output with converter operation, the motors will be used in temperature class 155 (F). To prevent damage as a result of bearing currents, insulated bearings are recommended to be assembled for frame size 250 and above. Please inquire Siemens about the detailed information of insulated bearing.

Converter operation

The standard insulation of our motors is designed such that operation is possible on the converter at mains voltage up to 460 V.

Our motors are capable for converter operation with certain characteristics load, of which the load torque characteristics is referred in the following diagram:

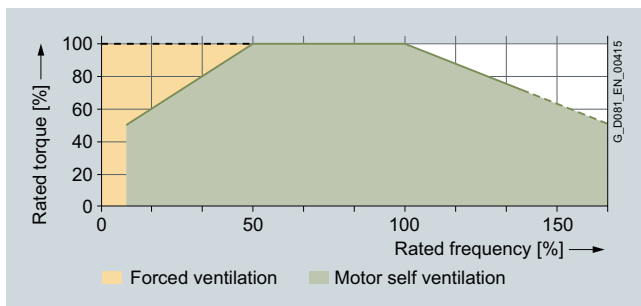

By usage with admissible torque and below, the motor can be operated with self cooling; by usage over the admissible torque line, the motor with forced ventilation is needed.

TIP



These motors do not have a special series for converter operation – they are suited as standard direct-on-line operation or converter operation.

At operating speeds above rated speed the noise and vibration levels increase and the bearing lifetime reduces. Attention should be paid to the re-greasing intervals and the grease service life. For converter operation with frequencies greater than 60 Hz special balancing is required for compliance with the specified limit values.

Voltage (peak and gradient) withstand levels

The dielectric stress of the winding insulation is determined by:

- the peak voltage, rise time and frequency of the impulses produced by the converter.
- the characteristics and the length of the connection leads between the converter and motor.
- the winding construction and other system parameters, especially the voltages between the different parts of the winding and the ground represent dielectric stress at the insulation system.

The standard insulation of our motors is designed to withstand voltage peak and gradient which is shown in the diagram:

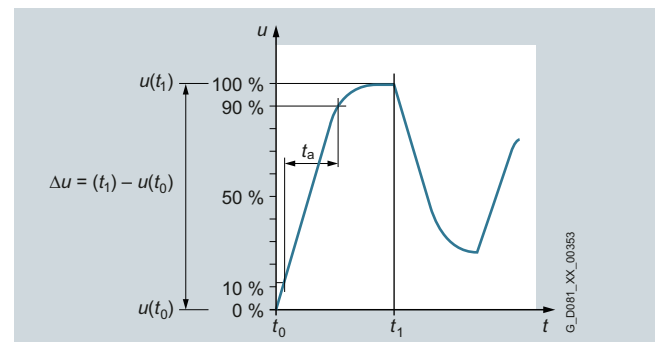
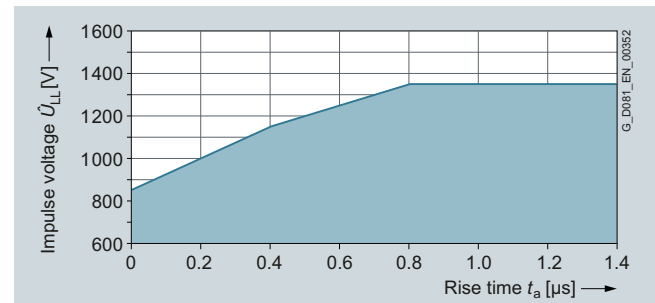

Did you know

As the motor gets larger so does the internal surface area between the stator and rotor. That surface has a stray capacitance which can lead to a voltage on the shaft – and that voltage can lead to bearing failure (bearing currents). The situation is aggravated by converter operation. Siemens recommends the use of insulated bearings for motors of frame size ≥ 250 . The insulated bearing as an option can be supplied on request for the 1LE0 series.

SIMOTICS General Purpose			
Frame size	Number of poles	Cast-iron series	
		IE1, IE2 & IE3 efficiencies 1LE002.	
		max. mechanical speed	f _{max}
80	2	5200	87
	4	3600	120
	6	2400	120
90	2	5200	87
	4	3600	120
	6	2400	120
100	2	5200	87
	4	3600	120
	6	2400	120
112	2	5200	87
	4	3600	120
	6	2400	120
132	2	4500	75
	4	2700	90
	6	2400	120
160	2	4500	75
	4	2700	90
	6	2400	120
180	2	3600	60
	4	2700	90
	6	2000	100
200	2	3600	60
	4	2300	77
	6	1800	90
225	2	3600	60
	4	2300	77
	6	1800	90
250	2	3600	60
	4	2300	77
	6	1800	90
280	2	3600	60
	4	2300	77
	6	1800	90
315	2	3600	60
	4	2300	77
	6	1800	90
355	2	3600	60
	4	2300	77
	6	1800	90

Mechanical stress and grease lifetime (converter operation).

High speeds that exceed the rated speed and the resulting increased vibrations alter the mechanical running smoothness and the bearings are subject to increased mechanical stress. This reduces the grease lifetime and the bearing lifetime. More detailed information on request.

Ventilation/noise generation (converter operation).

The fan noise can increase at speeds that are higher than the rated speed of self-ventilated motors. To increase motor utilization at low speeds it is recommended that forced ventilated motors are used.

Mechanical limit speeds

When the motor is operated at its rated frequency, it is important to note that the maximum speeds are limited by the limits for the roller bearings, critical rotor speed and rigidity of the rotating parts.

With converter operation, the reduction factors for constant torque and drives for fans, pumps and compressors must be observed.



TIP 

By use of converter operation, motors can run at speeds higher than 50 Hz or 60 Hz nominal speed. High speeds that exceed the rated speed of a motor can lead to increased vibration and substantially decrease the life expectancy of the bearings. The maximum mechanical speed of a motor must not be exceeded due to risk of failure. More detailed information on request.

Noise

Motors are often used in applications in which noise is a primary concern. The use of converters can excite the surfaces of motors and the sound of diverse frequencies can be resonated in the cooling channels.

Siemens has addressed this issue but modifying the core design.

Surfaces, shapes and materials and air channels have been optimized. The result is a motor which is quieter, especially with converter operation.

In order to define the motor noise level, the A-weighted sound pressure level (L_A) is measured at several points on the measuring plane (1 m away from the motor surface). The measurement is carried out in a room with low reflection. As a result of noise reflection, the level can be increased up to 3 dB(A) depending on the acoustic properties of the surroundings.

The A sound power level is normally used when engineering projects and when it is necessary to determine the noise radiated from a group of motors whose envelope dimensions differ significantly.

SIMOTICS General Purpose									
Output (kW)	Sound pressure level L_{pfa} / Sound power level L_{WA} (dB(A))								
	Cast-iron series								
	IE1 efficiency 1LE0022			IE2 efficiency 1LE0021			IE3 efficiency 1LE0023		
	3000 rpm (2-pole)	1500 rpm (4-pole)	1000 rpm (6-pole)	3000 rpm (2-pole)	1500 rpm (4-pole)	1000 rpm (6-pole)	3000 rpm (2-pole)	1500 rpm (4-pole)	1000 rpm (6-pole)
0.55	–	45/57	44/56	–	45/57	44/56	–	45/56	44/55
0.75	53/65	45/57	48/60	53/65	45/57	48/60	54/65	45/56	45/57
1.1	53/65	48/60	48/60	53/65	47/59	48/60	54/65	47/59	45/57
1.5	60/72	48/60	54/66	60/72	47/59	52/64	57/69	47/59	49/61
2.2	60/72	57/69	54/66	60/72	55/67	54/66	57/69	52/64	53/65
3	64/76	57/69	57/69	62/74	55/67	56/69	62/74	52/64	57/69
4	65/77	57/69	57/69	63/75	55/67	56/69	65/77	53/65	57/69
5.5	68/80	58/71	57/69	66/79	57/70	56/69	67/79	59/71	57/69
7.5	68/80	58/71	61/73	66/79	57/70	60/73	67/79	59/71	61/73
11	70/83	61/74	61/73	67/80	60/73	60/73	69/81	61/73	61/73
15	70/83	61/74	61/74	67/80	60/73	61/74	69/81	61/73	59/73
18.5	70/83	63/76	65/78	67/80	61/74	65/78	69/81	63/76	59/73
22	72/85	63/76	65/78	69/82	61/74	65/78	70/83	63/76	59/73
30	76/90	65/78	66/80	71/84	63/76	65/79	71/84	63/76	60/74
37	76/90	66/80	66/80	71/84	63/77	65/79	71/84	65/78	62/76
45	76/90	66/79	66/80	74/88	63/77	65/79	72/85	65/78	64/78
55	78/92	67/81	66/80	74/88	64/78	65/79	75/89	66/79	64/78
75	79/93	70/84	70/84	74/88	66/80	66/80	77/91	66/80	69/83
90	79/93	70/84	70/84	76/90	66/80	66/80	77/91	66/80	69/83
110	80/94	76/90	70/84	78/92	69/83	68/82	78/92	74/88	69/83
132	80/94	76/90	70/84	78/92	69/83	68/83	78/92	74/88	69/83
160	80/94	78/92	77/92	81/95	69/83	72/87	78/92	74/88	71/85
185	85/98	78/92	77/92	81/95	74/88	75/90	78/92	74/88	71/85
200	85/98	78/92	77/92	81/95	74/88	75/90	81/95	74/88	71/85
220	86/101	86/101	77/92	86/101	82/97	75/90	85/100	81/95	71/85
250	86/101	86/101	–	86/101	82/97	–	85/100	81/95	71/85
280	88/103	86/101	–	88/103	85/100	–	85/100	81/95	–
315	88/103	86/101	–	88/103	85/100	–	85/100	81/95	–

Bearings

The bearings are especially important in order that the motor runs perfectly. A good selection of bearing will guarantee long lubrication intervals, low noise, low-vibration operation and longer lifetime as well.

There are many types of bearing: diverse ball and roller bearings, tapered roller bearings and specialized bearings. Siemens has selected an applicable range of single-shielded and double-shielded bearings. Z for when regreasing is needed and ZZ when no-regreasing is wished for. Sealed-for-life bearings are avoided as they bring inherent disadvantages in operation temperatures and limit operating speeds.

Special bearings are avoided due to their disadvantages outside of their specific application.

The bearing lifetime of motors with horizontal type of construction is at least 40000 hours if there is no additional axial loading at the coupling output and at least 20000 hours with the maximum admissible loads.

This assumes that the motor is operated at 50 Hz.

A bearing is only as good as its lubrication. Unirex N3 is used for 1LE0 motors.

It gives a super thermal stability for optimized bearing life. The grease gives a great temperature range from -30 to 130 °C – with an intermittent temperature reserve to 165 °C.

Frame size	Number of poles	Grease lifetime up to CT 40 °C ¹⁾
Grease for bearings with permanent lubrication		
80 ... 250	2, 4, 6	20000 or 40000 (h) ²⁾
Grease for regreasable bearings		
100 ... 160	2, 4, 6	8000 (h)
180 ... 250	2	4000 (h)
180 ... 250	4, 6	8000 (h)
280 ... 315	2	3000 (h)
280 ... 315	4, 6	5000 (h)
355	2	3000 (h)
355	4, 6	4000 (h)

- ¹⁾ If the coolant temperature is increased by 10 K, the grease lifetime and regreasing interval are halved.
- ²⁾ 40000 h apply to horizontally installed motors with coupling output without additional axial loads.

TIP



Factors that reduce the lifetime of a bearing:

- Operating a motor beyond the rated speed increases the motor vibration and results in an additional radial and axial force on the bearing.
- Increased motor vibration due to the environment or other equipment results in an higher radial and axial force.

Cantilever force

This force acts transversely at the center line of the motor shaft extension. The cantilever force is calculated from the circumferential force multiplied by the pre-tension factor, which is dependent on the mechanical transmission characteristics of the particular belt.

For motors with deep-groove ball bearings, the permissible cantilever force can be increased by replacing the bearings at the drive end with cylindrical roller bearings.

In order to calculate the admissible cantilever forces for a radial load, the line of force (i.e. the center line of the pulley) of the cantilever force F_Q (N) must lie within the free shaft extension (dimension x).

Dimension x [mm] is the distance between the point of application of force F_Q and the shaft shoulder.

Dimension x_{max} corresponds to the length of the shaft extension. Total cantilever force is calculated using the following equation.

$$F_Q = c \cdot F_U$$

The pre-tension factor c is a value gained from experience by the belt manufacturer. The following approximate value can be assumed.

- For normal flat leather belts with an idler pulley, $c = 2$.
- For V-belts, $c = 2$ to 2.5 .
- For special synthetic belts (depending on the type and load), $c = 2$ to 2.5 .

The circumferential force F_U (N) is calculated using the following equation.

$$F_U = 2 \cdot 10^7 \frac{P}{n \times D}$$

F_U = circumferential force in N

P = rated motor power (transmitted power) in kW

n = rated motor speed

D = pulleys in mm.

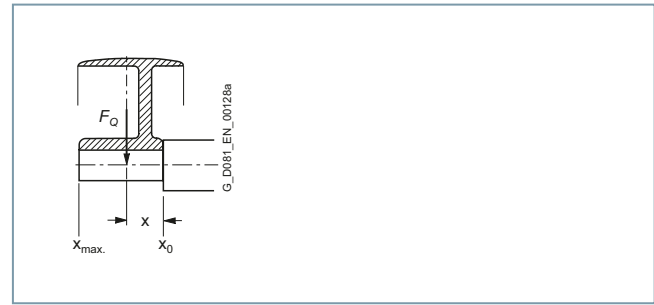

Belt drive

A belt drive is used to connect two parallel shafts, the motor shaft with the shaft of the driven machine, whereby the speed can be simultaneously changed corresponding to the ratio between the two belt pulley diameters.

The belt must be pre-tensioned so that it can transmit the circumferential force through friction. The pre-tension factor indicates how much higher the actual tension load (cantilever force) is than the circumferential force (peripheral force).

Today, flat belts are almost always manufactured out of plastic with an adhesive coating (e.g. chrome leather). Pre-tension factor, approx. 2 to 2.5. The pre-tension factor for V-belts is approx. 1.5 to 2.5.

The belt must be able to transmit the power at the defined circumferential velocity. This defines the belt thickness and width. The belt supplier specifies the pre-tension factor. The recommended circumferential velocity is approx. 35 m/s for flat belts and approx. 25 m/s for V-belts. Steel belt pulleys must be used for circumferential velocities greater than 26 m/s due to the centrifugal force which occurs.

The actual cantilever force (belt tension) must be compared with the cantilever force permissible for the motor to select the correct motor and bearing sizes.

Bearings – Bearing types

1LE0023									
Frame size	Number of poles	standard bearing assignment			Bearing design for increased cantilever forces (L22)			Re-greasing bearing (Option code:L23)	
		Drive end	Non-drive end (Horizontal mounting) (Vertical mounting)		Drive end	Non-drive end (Horizontal mounting) (Vertical mounting)		DE bearing	NDE bearing
80	2, 4, 6	6204 2Z C3	6204 2Z C3	6204 2Z C3	–	–	–	–	–
90	2, 4, 6	6205 2Z C3	6205 2Z C3	6205 2Z C3	–	–	–	–	–
100	2, 4, 6	6206 2Z C3	6206 2Z C3	6206 2Z C3	6306 2Z C3	6206 2Z C3	6206 2Z C3	6206 C3	6206 C3
112	2, 4, 6	6206 2Z C3	6206 2Z C3	6206 2Z C3	6306 2Z C3	6206 2Z C3	6206 2Z C3	6206 C3	6206 C3
132	2, 4, 6	6208 2Z C3	6208 2Z C3	6208 2Z C3	6308 2Z C3	6208 2Z C3	6208 2Z C3	6208 C3	6208 C3
160	2, 4, 6	6209 2Z C3	6209 2Z C3	6209 2Z C3	6309 2Z C3	6209 2Z C3	6209 2Z C3	6209 C3	6209 C3
180	2, 4, 6	6210 Z C3	6210 Z C3	6210 Z C3	NU210	6210 Z C3	6210 Z C3	6210 C3	6210 C3
200	2, 4, 6	6212 Z C3	6212 Z C3	6212 Z C3	NU212	6212 Z C3	6212 Z C3	6212 C3	6212 C3
225	2, 4, 6	6213 Z C3	6213 Z C3	6213 Z C3	NU213	6213 Z C3	6213 Z C3	6213 C3	6213 C3
250	2, 4, 6	6215 C3	6215 C3	6215 C3	NU215	6215 C3	6215 C3	6215 C3	6215 C3
280	2, 4, 6	6317 C3	6317 C3	6317 C3	NU317	6317 C3	6317 C3	□	□
315	2	6316 C3	6316 C3	6316 C3	NU316	6316 C3	6316 C3	□	□
	4, 6	6319 C3	6319 C3	6319 C3	NU319	6319 C3	6319 C3	□	□
355	2	6317 C3	6317 C3	7317	NU317	6317 C3	7317	□	□
	4, 6	6322 C3	6322 C3	7322	NU322	6322 C3	7322	□	□

1LE0021/2									
Frame size	Number of poles	standard bearing assignment			Bearing design for increased cantilever forces (L22)			Re-greasing bearing (Option code:L23)	
		Drive end	Non-drive end (Horizontal mounting) (Vertical mounting)		Drive end	Non-drive end (Horizontal mounting) (Vertical mounting)		DE bearing	NDE bearing
80	2, 4, 6	6204 2Z C3	6204 2Z C3	6204 2Z C3	–	–	–	–	–
90	2, 4, 6	6205 2Z C3	6205 2Z C3	6205 2Z C3	–	–	–	–	–
100	2, 4, 6	6206 2Z C3	6206 2Z C3	6206 2Z C3	6306 2Z C3	6206 2Z C3	6206 2Z C3	6206 C3	6206 C3
112	2, 4, 6	6206 2Z C3	6206 2Z C3	6206 2Z C3	6306 2Z C3	6206 2Z C3	6206 2Z C3	6206 C3	6206 C3
132	2, 4, 6	6208 2Z C3	6208 2Z C3	6208 2Z C3	6308 2Z C3	6208 2Z C3	6208 2Z C3	6208 C3	6208 C3
160	2, 4, 6	6209 2Z C3	6209 2Z C3	6209 2Z C3	6309 2Z C3	6209 2Z C3	6209 2Z C3	6209 C3	6209 C3
180	2, 4, 6	6210 Z C3	6210 Z C3	6210 Z C3	NU210	6210 Z C3	6210 Z C3	6210 C3	6210 C3
200	2, 4, 6	6212 Z C3	6212 Z C3	6212 Z C3	NU212	6212 Z C3	6212 Z C3	6212 C3	6212 C3
225	2, 4, 6	6213 Z C3	6213 Z C3	6213 Z C3	NU213	6213 Z C3	6213 Z C3	6213 C3	6213 C3
250	2, 4, 6	6215 C3	6215 C3	7215	NU215	6215 C3	7215	6215 C3	6215 C3
280	2, 4, 6	6317 C3	6317 C3	7317	NU317	6317 C3	7317	□	□
315	2	6319 C3	6319 C3	7319	NU319	6319 C3	7319	□	□
	4, 6	6319 C3	6319 C3	7319	NU319	6319 C3	7319	□	□
355	2	6319 C3	6319 C3	7319	NU319	6319 C3	7319	□	□
	4, 6	6322 C3	6322 C3	7322	NU322	6322 C3	7322	□	□

Bearings – Cantilever forces

Admissible cantilever forces for standard version

SIMOTICS General Purpose					
Frame size	Number of poles	Admissible cantilever forces standard version		increased cantilever forces (L22)	
		1LE0023		1LE0023	
		for x_0 N	for x_{max} N	for x_0 N	for x_{max} N
80	2	620	510	–	–
	4	790	640	–	–
	6	910	740	–	–
90	2	700	560	–	–
	4	880	720	–	–
	6	1020	820	–	–
100	2	980	790	1480	1220
	4	1230	990	1870	1540
	6	1420	1140	2140	1720
112	2	980	790	1480	1220
	4	1230	990	1870	1540
	6	1420	1140	2140	1720
132	2	1440	1120	2100	1700
	4	1820	1420	2720	2170
	6	2080	1630	3100	2420
160	2	1560	1240	2650	2120
	4	1970	1570	3300	2600
	6	2260	1800	3750	2900
180	2	1820	1470	3300	2700
	4	2300	1900	4200	3400
	6	2630	2150	4750	3900
200	2	2650	2230	5000	4200
	4	3350	2800	6330	5320
	6	3850	3230	7250	6080
225	2	3000	2540	5650	4800
	4	3700	3000	6950	5600
	6	4250	3470	7900	6500
250	2	3150	2620	6700	5600
	4	3950	3280	8500	7000
	6	4600	3820	9500	7800
280	2	6600	5550	11500	9500
	4	8300	6950	17000	14000
	6	9650	8120	20000	17000
315	2	5850	5060	11000	9170
	4	8700	7250	20000	16500
	6	10000	8500	23000	19000
355	2	6110	5420	12700	11200
	4	11500	10000	22000	19000
	6	13200	11600	25000	22000

Bearings – Cantilever forces

Admissible cantilever forces for standard version

SIMOTICS General Purpose					
Frame size	Number of poles	Admissible cantilever forces standard version		increased cantilever forces (L22)	
		1LE0021/2		1LE0021/2	
		for x_0 N	for x_{max} N	for x_0 N	for x_{max} N
80	2	620	510	–	–
	4	790	640	–	–
	6	910	740	–	–
90	2	700	560	–	–
	4	880	720	–	–
	6	1020	820	–	–
100	2	980	790	1480	1220
	4	1230	990	1870	1540
	6	1420	1140	2140	1720
112	2	980	790	1480	1220
	4	1230	990	1870	1540
	6	1420	1140	2140	1720
132	2	1440	1120	2100	1700
	4	1820	1420	2720	2170
	6	2080	1630	3100	2420
160	2	1560	1240	2650	2120
	4	1970	1570	3300	2600
	6	2260	1800	3750	2900
180	2	1820	1470	3300	2700
	4	2300	1900	4200	3400
	6	2630	2150	4750	3900
200	2	2650	2230	5000	4200
	4	3350	2800	6330	5320
	6	3850	3230	7250	6080
225	2	3000	2540	5650	4800
	4	3700	3000	6950	5600
	6	4250	3470	7900	6500
250	2	3150	2620	6700	5600
	4	3950	3280	8500	7000
	6	4600	3820	9500	7800
280	2	6600	5550	11500	9500
	4	8300	6950	17000	14000
	6	9650	8120	20000	17000
315	2	7100	6200	14600	12300
	4	8700	7250	20000	16500
	6	10000	8500	23000	19000
355	2	6800	6000	15800	14000
	4	11500	10000	22000	19000
	6	13200	11600	25000	22000

Terminal box

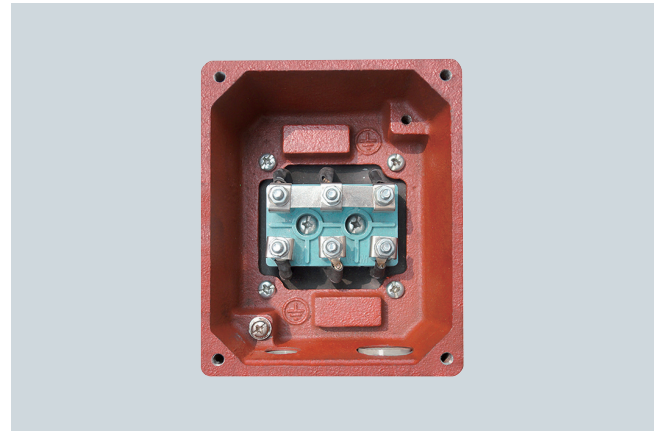

Frame size	Cast-iron series				
	IE1, IE2 and IE3 efficiencies				
	Number of terminals	Contact screw thread	1LE0 Max. connectable cross-section (mm ²)	Outer cable diameter (sealing range)	Cable entry size (screwed plug)
80	6	M4	1.5	13 ... 18	M25 × 1.5 + M16 × 1.5
90	6	M4	1.5	13 ... 18	M25 × 1.5 + M16 × 1.5
100	6	M4	4	18 ... 25	M32 × 1.5 + M32 × 1.5
112	6	M4	4	18 ... 25	M32 × 1.5 + M32 × 1.5
132	6	M4	6	18 ... 25	M32 × 1.5 + M32 × 1.5
160	6	M5	16	22 ... 32	M40 × 1.5 + M40 × 1.5
180	6	M5	16	22 ... 32	M40 × 1.5 + M40 × 1.5
200	6	M6	25	32 ... 38	M50 × 1.5 + M50 × 1.5
225	6	M8	35	32 ... 38	M50 × 1.5 + M50 × 1.5
250	6	M10	120	37 ... 44	M63 × 1.5 + M63 × 1.5
280	6	M10	120	37 ... 44	M63 × 1.5 + M63 × 1.5
315	6	M12	240	37 ... 44	M63 × 1.5 + M63 × 1.5
355	6	M16	240	44 ... 57	M72 × 2 + M72 × 2

Packaging size

Frame size	Cast-iron series					
	Packaging size mm					
	IE1 and IE2 efficiencies			IE3 efficiency		
	Length	1LE0 Width	High	Length	1LE0 Width	High
80	335	225	280	395	225	280
90	400	225	290	455	225	290
100	445	275	335	515	275	335
112	455	275	350	555	275	350
132	565	335	405	665	335	405
160	730	460	580	730	460	580
180	800	440	630	800	440	630
200	880	510	695	880	510	695
225	960	560	735	960	560	735
250	980	640	810	980	640	810
280	1090	650	920	1090	650	920
315	1390	760	1060	1630	760	1060
355	1650	930	1260	1650	930	1260



Did you know

Power

Power is the work performed in a unit of time, measured in W (Watt).

Dimensions:

$$\begin{aligned}
 1 \text{ W} &= \text{J/s (1 Joule per second)} \\
 &= 1 \text{ Nm/s (1 Newton meter per second)} \\
 &= 1 \text{ kgm}^2/\text{s}^3 \\
 &= 0.102 \text{ kpm/s} \\
 1 \text{ kW} &= 1.36 \text{ hp}
 \end{aligned}$$

The following applies to three-phase motors:

$$P_N = \sqrt{3} \cdot V_{\text{supply}} \cdot I_{\text{supply}} \cdot \eta \cdot \cos \Phi$$

P_N	Rated power in W
V	Rated voltage in V
I	Line current in A
η	Efficiency
$\cos \Phi$	Power factor

The rated power is one of the most important parameters of a motor. According to DIN 42673 – and maintaining the regulations according to VDE 0530 – the individual motor frame sizes are assigned specific power ratings for continuous duty S1. Different operating conditions or different duty types generally result in a change in the rated power.



Did you know

Torque

Torque is generated by the effect of force applied to a lever arm. This is the product of force multiplied by the vertical distance from the axis of rotation; for belt drives, e.g. circumferential force multiplied by the radius of the belt pulley.

$$M = 9.55 \cdot P \cdot \frac{1000}{n}$$

M	Torque in Nm
P	Power in kW
n	Speed in rpm



Did you know

Speed

The synchronous speed n_s (rpm) of a three-phase induction motor is obtained from the line frequency f and the pole pair number p (4-pole $\rightarrow 2p = 4$).

$$n_s = \frac{120 \cdot f}{2 \cdot p}$$

When connected to a 50 Hz line supply, a $2p = 4$ -pole motor has a synchronous speed of

$$\frac{120 \cdot 50}{4} = 1500 \text{ rpm}$$

The synchronous speeds of the generally used 2, 4, and 6-pole motors are correspondingly obtained

- at a line frequency of 50 Hz
3000, 1500, 1000 rpm
- at a line frequency of 60 Hz
3600, 1800, 1200 rpm

The rotor of a three-phase induction motor rotates with a lower speed (with slip) than the rotating field.

Slip s is calculated according to the following formula:

$$s = \frac{n_s - n}{n_s} \cdot 100$$

s	Slip as a %
n_s	Synchronous speed in rpm
n	Rotor speed in rpm

The rated slip s_N is correspondingly calculated. The rotor losses of the motor are approximately proportional to the slip. The objective is to achieve a low rated slip in order to achieve a good efficiency. The rated slip depends on the motor size. For instance, for small motors, it is approx. 10% and for large motors, approx. 1%.

Handling and storage

When lifting the motors, always use the lifting eyes provided. Prior to lifting the motor make sure that the lifting eyes are installed correctly and tightened. Never lift a motor using the rotor shaft and fan cover. In addition, care must be taken during lifting and lowering of the motor to avoid any shocks or vibrations which can result in bearing damages.

It is recommended that all motors be stored in a dry, dust-free environment and free of excessive vibrations.

If the DE and NDE bearings are of the sealed types, it is recommended that they are replaced if storage has exceeded 2 years from date of motor manufacture. If the motors have the regreasable bearings, then the recommendation is to replace the grease after 2 years of storage.

The service life of the motor can be considerably reduced if the storage period extends beyond 2 years in environments with high moisture and dirt. If necessary, the insulation resistance of the winding could be measured to determine the health of the motor prior to installation and start-up.

Machined surfaces (flange, DE rotor shaft) are treated at the factory with an anticorrosive agent to prevent rusting. However, these surfaces should be retreated during storage as deemed necessary. It is recommended that the motor shaft is rotated by hand on a frequent basis to ensure even grease distribution.

Certificates

ISO 9001 Quality Management System Certificate



ISO 14001 Environmental Management System Certificate



SIMOTICS Option Line

SIMOTICS Option Line – Motor selection and article number code

Overview

The article number consists of a combination of figures and letters and is divided into three blocks linked with hyphens for a better overview.

The first block (Position 1 to 7) identifies the motor type and efficiency level; the second block (Position 8 to 12)

defines the motor frame size and length, the number of poles and in some cases the frequency/output; and in the third block (Position 13 to 16) the frequency/output, type of construction and other design features are encoded.

Article number code

Structure	Position: 1 2 3 4 5 6 7 - 8 9 10 11 12 - 13 14 15 16 - Z
<u>Position 1 to 6:</u>	Low-voltage motor series • 1LE0 Option Line
<u>Position 7:</u>	Motor efficiency • Motor with High Efficiency – IE2 • Motor with Standard Efficiency – IE1 • Motor with Premium Efficiency – IE3
<u>Position 8 to 11:</u>	Frame size, number of poles and frame length Refer to page 36
<u>Position 12 and 13:</u>	Voltage, circuit and frequency • 22: 230 VΔ/400 VY 50 Hz • 34: 400 VΔ/690 VY 50 Hz • 35: 415 VΔ 50 Hz • 21: 220 VΔ/380 VY 50 Hz • 33: 380 VΔ/660 VY 50 Hz • 90 ^(a) : special voltage & frequency • 23: 240 VΔ/415 VY 50 Hz • 41: 525 VΔ 50 Hz
<u>Position 14:</u>	Type of construction (refer to page 14) • A: IM B3 • J: IM B35 • F: IM B5 • G: IM V1 • K: IM B14 • T: IM B6 • U: IM B7 • V: IM B8 • C: IM V5 • D: IM V6 • N: IM B34 • M: IM V18 • L: IM V19 • W: IM V15 • Y: IM V35 • H: IM V3
<u>Position 15:</u>	Motor protection • A: without winding protection • B: 3 PTC thermistors for tripping • C: 6 PTC thermistors for alarm and tripping • K: 1 single 2 wires PT1000 resistance thermometers • H: 3 resistance thermometers Pt100 • J: 6 resistance thermometers Pt100
<u>Position 16:</u>	Terminal box position (view from drive end) • 4: Terminal box top • 5: Terminal box right • 6: Terminal box left
	Special order versions Encoded – additional order (option) code required ^(a)

^(a) For deviations in the second and third block from the catalog codes, -Z or 90 should be used as alphanumeric values appropriate, e.g. 1LE0021-1DB43-4AB4-Z B02; or 1LE0021-1DB49-0AB4 M2A.

Ordering example

1LE0021-1DB43-4AH4-Z F70+B02

1LE0 Option Line motor, IE2 High Efficiency motor, FS 160, 4-pole, 400 VΔ/690 VY 50 Hz, IM B3, 3 resistance thermometers Pt100, terminal box top included separately driven fan (F70) and acceptance test certificate 3.1 in accordance with EN 10204 (B02).

Motor selection

Here is our comprehensive distribution motor portfolio, offering cast-iron series IE1, IE2 and IE3 efficiencies.

Our portfolio is covering power ratings from 0.55 up to 315 kW and frame sizes 80 to 355.

Did you know

All our described motors have a repeated starting capability. Those motors used on a frequency converter ramping quickly from 0 Hz do not overheat and have an unlimited starting capability. (also see section “converter application”) Those motors started direct on-line heat slightly each time they start. The number of starts can only be calculated if many parameters are known. As a rule, three successive normal starts for a cold motor and two successive starts for a warm motor are accepted.

SIMOTICS General Purpose									
Cast-iron series									
Efficiency class	IE1			IE2			IE3		
Series	1LE0022			1LE0021			1LE0023		
No. of poles	2	4	6	2	4	6	2	4	6
Cooling	Self-ventilated (IC 411)			Self-ventilated (IC 411)			Self-ventilated (IC 411)		
Degree of protection	IP55			IP55			IP55		
Insulation	Thermal class 155 (F)			Thermal class 155 (F)			Thermal class 155 (F)		
Utilization	Thermal class 130 (B)			Thermal class 130 (B)			Thermal class 130 (B)		
Frame size	80 ... 355			80 ... 355			80 ... 355		
Rated output at 50 Hz	0.55 ... 315 kW			0.55 ... 315 kW			0.55 ... 315 kW		
Rated torque at 50 Hz	2.6 ... 2414 Nm			2.6 ... 2412 Nm			2.5 ... 2406.8 Nm		
Rated power (kW)									
0.55	–	✓	✓	–	✓	✓	–	✓	✓
0.75	✓	✓	✓	✓	✓	✓	✓	✓	✓
1.1	✓	✓	✓	✓	✓	✓	✓	✓	✓
1.5	✓	✓	✓	✓	✓	✓	✓	✓	✓
2.2	✓	✓	✓	✓	✓	✓	✓	✓	✓
3	✓	✓	✓	✓	✓	✓	✓	✓	✓
4	✓	✓	✓	✓	✓	✓	✓	✓	✓
5.5	✓	✓	✓	✓	✓	✓	✓	✓	✓
7.5	✓	✓	✓	✓	✓	✓	✓	✓	✓
11	✓	✓	✓	✓	✓	✓	✓	✓	✓
15	✓	✓	✓	✓	✓	✓	✓	✓	✓
18.5	✓	✓	✓	✓	✓	✓	✓	✓	✓
22	✓	✓	✓	✓	✓	✓	✓	✓	✓
30	✓	✓	✓	✓	✓	✓	✓	✓	✓
37	✓	✓	✓	✓	✓	✓	✓	✓	✓
45	✓	✓	✓	✓	✓	✓	✓	✓	✓
55	✓	✓	✓	✓	✓	✓	✓	✓	✓
75	✓	✓	✓	✓	✓	✓	✓	✓	✓
90	✓	✓	✓	✓	✓	✓	✓	✓	✓
110	✓	✓	✓	✓	✓	✓	✓	✓	✓
132	✓	✓	✓	✓	✓	✓	✓	✓	✓
160	✓	✓	✓	✓	✓	✓	✓	✓	✓
185	✓	✓	✓	✓	✓	✓	✓	✓	✓
200	✓	✓	✓	✓	✓	✓	✓	✓	✓
220	✓	✓	✓	✓	✓	✓	✓	✓	✓
250	✓	✓	✓	✓	✓	✓	✓	✓	✓
280	✓	✓	–	✓	✓	–	✓	✓	–
315	✓	✓	–	✓	✓	–	✓	✓	–

✓ = Available
– = Not available

SIMOTICS Option Line – IE1

Cast-iron series	
Efficiency class	IE1
Series	1LE0022
No. of poles	2 4 6
Cooling	Self-ventilated (IC 411)
Degree of protection	IP55
Insulation	Thermal class 155 (F)
Utilization	Thermal class 130 (B)
Frame size	80 ... 355
Rated output at 50 Hz	0.55 ... 315 kW
Rated torque at 50 Hz	2.6 ... 2414 Nm



TIP
 The nominal torque of the motor is easy to calculate;
 Torque (Nm) =
 Power (kW) × 9550 / Speed (rpm).

Electrical data – 1LE0 – IE1 – 2-pole		(IE1 cast iron) 3000 rpm 2-pole, 400 V 50 Hz														
Rated output		Frame size	Article number	IE class	Rated speed	Rated torque	Rated current	Rated power factor	Efficiency at			Starting current	Starting torque	Break-down torque	Moment of inertia	Net weight (IM B3)
50 Hz kW	60 Hz kW								100% load %	75% load %	50% load %					
230 VΔ / 400 VY																
0.75	0.86	80 M	1LE0022-0DA22-2...	IE1	2795	2.6	1.79	0.84	72.1	73	71.1	5.1	2.3	2.7	0.0008	15
1.1	1.3	80 M	1LE0022-0DA32-2...	IE1	2830	3.7	2.5	0.84	75	77.3	74.4	6	2.6	3.1	0.0012	16
1.5	1.75	90 S	1LE0022-0EA02-2...	IE1	2885	5	3.50	0.84	77.2	76.9	73.5	6.9	2.5	3.2	0.0021	20
2.2	2.55	90 L	1LE0022-0EA42-2...	IE1	2885	7.3	4.70	0.85	79.7	80.5	78.1	7.5	2.7	3.4	0.0026	23
3	3.45	100 L	1LE0022-1AA42-2...	IE1	2850	10	6.3	0.85	81.5	82.1	79.9	6.9	3	3.7	0.0036	33
400 VΔ / 690 VY																
4	4.6	112 M	1LE0022-1BA23-4...	IE1	2910	13.1	8.2	0.85	83.1	83.7	81.5	7.8	2.9	4.2	0.0064	39
5.5	6.3	132 S	1LE0022-1CA03-4...	IE1	2915	18	10.9	0.86	84.7	85.3	83.7	6.9	2	3.1	0.014	54
7.5	8.6	132 S	1LE0022-1CA13-4...	IE1	2920	24.5	14.1	0.89	86	87.2	86.2	7.1	2	2.9	0.017	63
11	12.6	160 M	1LE0022-1DA23-4...	IE1	2925	35.9	21.5	0.85	87.6	88.2	87.1	6.3	2	3.1	0.031	99
15	17.3	160 M	1LE0022-1DA33-4...	IE1	2930	48.9	28.5	0.85	88.7	89.3	87.4	7	2.2	3.2	0.038	109
18.5	21.3	160 L	1LE0022-1DA43-4...	IE1	2935	60	35	0.86	89.3	89.9	89.1	7.6	2.5	3.4	0.046	122
22	24.5	180 M	1LE0022-1EA23-4...	IE1	2935	72	40.5	0.87	89.9	90.6	90	7.6	2.7	3.5	0.072	155
30	33.5	200 L	1LE0022-2AA43-4...	IE1	2950	97	55	0.87	90.7	90.8	89	7.5	2.5	3.2	0.13	219
37	41.5	200 L	1LE0022-2AA53-4...	IE1	2950	120	67	0.88	91.2	91.6	90.4	7.4	2.6	3.2	0.15	235
45	51	225 M	1LE0022-2BA23-4...	IE1	2960	145	81	0.88	91.7	91.9	90.5	7.6	2.8	3.3	0.24	295
55	62	250 M	1LE0022-2CA23-4...	IE1	2970	177	98	0.88	92.1	92.4	90.7	7.7	2.5	3.1	0.42	361
75	84	280 S	1LE0022-2DA03-4...	IE1	2970	241	134	0.87	92.7	92.6	91.1	6.7	2.7	3	0.75	484
90	101	280 M	1LE0022-2DA23-4...	IE1	2975	289	159	0.88	93	93.2	91.3	7.2	2.8	3	0.88	550
110	123	315 S	1LE0022-3AA03-4...	IE1	2982	353	189	0.9	93.3	93.1	91.2	7.5	2.2	3.1	1.4	715
132	148	315 M	1LE0022-3AA23-4...	IE1	2980	423	220	0.92	93.5	93.1	91.7	7.5	2.3	2.9	1.7	880
160	180	315 L	1LE0022-3AA53-4...	IE1	2982	513	265	0.92	93.8	93.6	92.5	7.6	2.5	2.8	1.9	930
185	207	315 L	1LE0022-3AA63-4...	IE1	2982	594	310	0.92	93.9	93.9	93.1	7.5	2.4	2.8	2.3	1080
200	224	315 L	1LE0022-3AA73-4...	IE1	2980	641	335	0.92	94	94.3	93.2	7.9	2.5	2.6	2.3	1090
220	246	355 M	1LE0022-3BA23-4...	IE1	2985	704	375	0.9	94.0	94.2	92.0	7	2	2.6	2.5	1410
250	280	355 M	1LE0022-3BA33-4...	IE1	2985	800	425	0.9	94.0	94.0	91.8	7.4	2.3	2.8	2.7	1480
280	314	355 L	1LE0022-3BA53-4...	IE1	2985	896	470	0.91	94.0	94.0	91.1	7	2.2	2.6	3	1550
315	353	355 L	1LE0022-3BA63-4...	IE1	2985	1008	530	0.91	94.0	94.0	91.8	7.4	2.5	2.8	3.3	1720

SIMOTICS Option Line – IE1

Cast-iron series	
Efficiency class	IE1
Series	1LE0022
No. of poles	2 4 6
Cooling	Self-ventilated (IC 411)
Degree of protection	IP55
Insulation	Thermal class 155 (F)
Utilization	Thermal class 130 (B)
Frame size	80 ... 355
Rated output at 50 Hz	0.55 ... 315 kW
Rated torque at 50 Hz	2.6 ... 2414 Nm



The nominal torque of the motor is easy to calculate;
 Torque (Nm) =
 Power (kW) × 9550 / Speed (rpm).

Electrical data – 1LE0 – IE1 – 4-pole		(IE1 cast iron) 1500 rpm 4-pole, 400 V 50 Hz														
Rated output 50 Hz kW	Rated output 60 Hz kW	Frame size	Article number	IE class	Rated speed rpm	Rated torque Nm	Rated current A	Rated power factor	Efficiency at			Starting current	Starting torque	Break- down torque	Moment of inertia kgm ²	Net weight (IM B3) kg
									100% load %	75% load %	50% load %					
230 VΔ / 400 VY																
0.55	0.63	80 M	1LE0022-0DB22-2...	IE1	1415	3.7	1.40	0.81	70.0	70.5	67.4	4.5	2	2.6	0.0021	15.5
0.75	0.86	80 M	1LE0022-0DB32-2...	IE1	1415	5.1	1.87	0.81	72.1	73.7	71.8	4.8	2	2.6	0.0027	17.5
1.1	1.3	90 S	1LE0022-0EB02-2...	IE1	1425	7.4	2.65	0.8	75	77.3	74.3	5.4	2	2.6	0.0041	20
1.5	1.75	90 L	1LE0022-0EB42-2...	IE1	1425	10	3.5	0.81	77.2	77.3	75.1	5.6	2	2.5	0.0047	24
2.2	2.55	100 L	1LE0022-1AB42-2...	IE1	1430	14.8	4.85	0.82	79.7	80.7	78.7	5.8	2.4	2.9	0.0081	33
3	3.45	100 L	1LE0022-1AB52-2...	IE1	1430	20.2	6.4	0.83	81.5	83.1	81.5	6.5	2.8	3.1	0.01	35
400 VΔ / 690 VY																
4	4.6	112 M	1LE0022-1BB23-4...	IE1	1445	26.4	8.8	0.79	83.1	83.3	81.5	7.4	2.8	3.3	0.011	43
5.5	6.3	132 S	1LE0022-1CB03-4...	IE1	1450	36.2	11.4	0.82	84.7	85.5	84.3	6.5	2	3.1	0.021	62
7.5	8.6	132 M	1LE0022-1CB23-4...	IE1	1435	50	15.0	0.84	86	87.2	87.2	6.4	2.3	3.1	0.029	74
11	12.6	160 M	1LE0022-1DB23-4...	IE1	1460	72	21.5	0.84	87.6	88.5	87.8	6.9	2.2	3.3	0.051	106
15	17.3	160 L	1LE0022-1DB43-4...	IE1	1465	98	29	0.84	88.7	89.4	88.6	7.8	2.7	3.8	0.066	124
18.5	21.3	180 M	1LE0022-1EB23-4...	IE1	1470	120	35.5	0.84	89.3	90.3	89.9	7.8	2.7	3.5	0.13	167
22	24.5	180 L	1LE0022-1EB43-4...	IE1	1465	143	41.5	0.85	89.9	90.9	89.9	7.8	2.4	3.2	0.14	183
30	33.5	200 L	1LE0022-2AB43-4...	IE1	1470	195	56	0.85	90.7	91.6	90.5	7.4	2.4	3.1	0.22	231
37	41.5	225 S	1LE0022-2BB03-4...	IE1	1470	240	68	0.86	91.2	91.8	91	7.3	2.3	2.8	0.45	287
45	51	225 M	1LE0022-2BB23-4...	IE1	1475	292	82	0.87	91.7	92.4	92	7.8	2.9	3.3	0.51	314
55	62	250 M	1LE0022-2CB23-4...	IE1	1478	356	101	0.86	92.1	92.8	92	7.6	3	2.8	0.8	394
75	84	280 S	1LE0022-2DB03-4...	IE1	1480	484	133	0.88	92.7	93.3	92.2	7.2	2.6	2.8	1.4	540
90	101	280 M	1LE0022-2DB23-4...	IE1	1485	579	159	0.88	93	93.5	92.2	7.8	2.7	2.8	1.5	595
110	123	315 S	1LE0022-3AB03-4...	IE1	1490	706	200	0.85	93.3	93.4	92.5	8.6	2.8	3.1	2.2	720
132	148	315 M	1LE0022-3AB23-4...	IE1	1488	848	230	0.88	93.5	93.8	93.4	7.3	2.5	2.7	2.5	850
160	180	315 L	1LE0022-3AB53-4...	IE1	1488	1030	285	0.87	93.8	94	93.6	7.4	3	2.9	3	930
185	207	315 L	1LE0022-3AB63-4...	IE1	1490	1185	325	0.88	93.9	94.1	93.6	7.6	3	2.9	3.6	1040
200	224	315 L	1LE0022-3AB73-4...	IE1	1488	1285	345	0.88	94	94.3	94.1	7.4	3	3	3.7	1050
220	246	355 M	1LE0022-3BB23-4...	IE1	1490	1411	380	0.89	94.0	94.1	92.1	6.9	1.7	2.5	4.9	1580
250	280	355 M	1LE0022-3BB33-4...	IE1	1490	1604	430	0.89	94.0	94.0	92.4	6.9	1.8	2.5	5	1640
280	314	355 L	1LE0022-3BB53-4...	IE1	1490	1795	485	0.89	94.0	94.0	92.2	7	1.9	2.7	5.3	1690
315	353	355 L	1LE0022-3BB63-4...	IE1	1490	2019	540	0.89	94.0	94.0	92.4	7	1.9	2.7	5.7	1790

SIMOTICS Option Line – IE1

Cast-iron series	
Efficiency class	IE1
Series	1LE0022
No. of poles	2 4 6
Cooling	Self-ventilated (IC 411)
Degree of protection	IP55
Insulation	Thermal class 155 (F)
Utilization	Thermal class 130 (B)
Frame size	80 ... 355
Rated output at 50 Hz	0.55 ... 315 kW
Rated torque at 50 Hz	2.6 ... 2414 Nm

TIP

The nominal torque of the motor is easy to calculate;
 Torque (Nm) =
 Power (kW) × 9550 / Speed (rpm).

Electrical data – 1LE0 – IE1 – 6-pole		(IE1 cast iron) 1000 rpm 6-pole, 400 V 50 Hz														
Rated output 50 Hz kW	Rated output 60 Hz kW	Frame size	Article number	IE class	Rated speed rpm	Rated torque Nm	Rated current A	Rated power factor	Efficiency at			Starting current	Starting torque	Break- down torque	Moment of inertia kgm ²	Net weight (IM B3) kg
									100% load %	75% load %	50% load %					
230 VΔ / 400 VY																
0.55	0.63	80 M	1LE0022-0DC32-2...	IE1	910	5.8	1.6	0.74	67.5	68.7	65.6	3.8	2.1	2.4	0.0028	17
0.75	0.86	90 S	1LE0022-0EC02-2...	IE1	930	7.7	2.1	0.74	70	71.5	68.9	3.9	2	2.5	0.0038	21
1.1	1.3	90 L	1LE0022-0EC42-2...	IE1	935	11.3	3	0.73	72.9	74	71.8	4.4	2.2	2.7	0.0046	26
1.5	1.75	100 L	1LE0022-1AC42-2...	IE1	940	15.4	3.8	0.76	75.2	77.2	74.7	4.6	2.1	2.6	0.0086	34
2.2	2.55	112 M	1LE0022-1BC22-2...	IE1	940	22.3	5.5	0.75	77.7	79.2	78.1	5.2	2.4	3	0.012	42
3	3.45	132 S	1LE0022-1CC02-2...	IE1	955	30	7.5	0.73	79.7	80.9	79.3	5.2	2	2.8	0.019	54
400 VΔ / 690 VY																
4	4.6	132 M	1LE0022-1CC23-4...	IE1	950	40	9.7	0.73	81.4	82.2	79.4	5.6	2.1	2.9	0.024	67
5.5	6.3	132 M	1LE0022-1CC33-4...	IE1	955	55	12.9	0.74	83.1	84.2	83	6	2.3	3.2	0.031	76
7.5	8.6	160 M	1LE0022-1DC23-4...	IE1	980	74	16.8	0.76	84.7	85.4	84.5	5.8	2	2.9	0.1069	107
11	12.6	160 L	1LE0022-1DC43-4...	IE1	980	109	24	0.76	86.4	87	86	6.6	2.2	3.1	0.14	127
15	17.3	180 L	1LE0022-1EC43-4...	IE1	970	148	32	0.78	87.7	88.7	88.4	6.5	2.3	3	0.18	165
18.5	21.3	200 L	1LE0022-2AC43-4...	IE1	975	182.1	36.5	0.82	88.6	90	90.1	5.8	2.2	2.8	0.27	225
22	24.5	200 L	1LE0022-2AC53-4...	IE1	975	215	43	0.82	89.2	90.5	90.5	6.5	2.3	2.8	0.32	231
30	33.5	225 M	1LE0022-2BC23-4...	IE1	978	293	58	0.83	90.2	91.4	90.5	6.7	2.4	2.8	0.62	298
37	41.5	250 M	1LE0022-2CC23-4...	IE1	982	360	71	0.83	90.8	91.5	91.2	7.5	3	2.8	0.91	376
45	51	280 S	1LE0022-2DC03-4...	IE1	985	437	84	0.85	91.4	92.4	92.3	7.1	2.5	2.8	1.2	456
55	62	280 M	1LE0022-2DC23-4...	IE1	988	532	102	0.85	91.9	92.6	92.4	7.5	2.4	2.7	1.5	545
75	84	315 S	1LE0022-3AC03-4...	IE1	988	725	138	0.85	92.6	93	92.4	7.5	2.4	3	2.3	680
90	101	315 M	1LE0022-3AC23-4...	IE1	986	872	165	0.85	92.9	93.4	93.2	7	2.3	2.8	2.8	835
110	123	315 L	1LE0022-3AC53-4...	IE1	986	1066	200	0.86	93.3	93.9	93.8	6.5	2.2	2.7	3.9	975
132	148	315 L	1LE0022-3AC63-4...	IE1	988	1278	235	0.86	93.5	94.2	93.6	7.8	2.2	2.4	4.3	1030
160	180	355 M	1LE0022-3BC23-4...	IE1	989	1542	285	0.87	93.8	93.9	91.7	7	2.4	2.2	8.9	1630
185	207	355 M	1LE0022-3BC33-4...	IE1	989	1783	325	0.87	93.9	94.0	92.0	7.1	2.6	2.6	9.4	1760
200	224	355 M	1LE0022-3BC43-4...	IE1	989	1930	355	0.87	94.0	94.0	92.7	7.1	2.6	2.6	10.5	1760
220	246	355 L	1LE0022-3BC53-4...	IE1	989	2121	390	0.87	94.0	94.0	91.9	7.6	2.6	2.6	11.5	1870
250	280	355 L	1LE0022-3BC63-4...	IE1	989	2408	440	0.87	94.0	94.0	92.7	7.8	2.8	2.7	12.9	1950

SIMOTICS Option Line – IE1

Cast-iron series			
Efficiency class	IE1		
Series	1LE0022		
No. of poles	2	4	6
Cooling	Self-ventilated (IC 411)		
Degree of protection	IP55		
Insulation	Thermal class 155 (F)		
Utilization	Thermal class 130 (B)		
Frame size	80 ... 355		
Rated output at 50 Hz	0.55 ... 315 kW		
Rated torque at 50 Hz	2.6 ... 2414 Nm		



TIP
 The nominal torque of the motor is easy to calculate;
 Torque (Nm) =
 Power (kW) × 9550 / Speed (rpm).

Electrical data – 1LE0 – IE1 – 2-pole (IE1 cast iron) 3000 rpm 2-pole, 380 VΔ 50 Hz															
Rated output kW	Frame size	Article number	IE class	Rated speed rpm	Rated torque Nm	Rated current A	Rated power factor	Efficiency at			Starting current	Starting torque	Break-down torque	Moment of inertia kgm ²	Net weight (IM B3) kg
								100% load %	75% load %	50% load %					
220 VΔ / 380 VY															
0.75	80 M	1LE0022-ODA22-1...	IE1	2795	2.6	1.88	0.84	72.1	73	71.1	5.1	2.3	2.7	0.0008	15
1.1	80 M	1LE0022-ODA32-1...	IE1	2830	3.7	2.65	0.84	75	77.3	74.4	6	2.6	3.1	0.0012	16
1.5	90 S	1LE0022-OEA02-1...	IE1	2885	5	3.35	0.84	77.2	76.9	73.5	6.9	2.5	3.2	0.0021	20
2.2	90 L	1LE0022-OEA42-1...	IE1	2885	7.3	4.95	0.85	79.7	80.5	78.1	7.5	2.7	3.4	0.0026	23
3	100 L	1LE0022-1AA42-1...	IE1	2850	10	6.6	0.85	81.5	82.1	79.9	6.9	3	3.7	0.0036	33
380 VΔ / 660 VY															
4	112 M	1LE0022-1BA23-3...	IE1	2910	13.1	8.6	0.85	83.1	83.7	81.5	7.8	2.9	4.2	0.0064	39
5.5	132 S	1LE0022-1CA03-3...	IE1	2915	18	11.5	0.86	84.7	85.3	83.7	6.9	2	3.1	0.014	54
7.5	132 S	1LE0022-1CA13-3...	IE1	2920	24.5	14.9	0.89	86	87.2	86.2	7.1	2	2.9	0.017	63
11	160 M	1LE0022-1DA23-3...	IE1	2925	35.9	22.5	0.85	87.6	88.2	87.1	6.3	2	3.1	0.031	99
15	160 M	1LE0022-1DA33-3...	IE1	2930	48.9	30.0	0.85	88.7	89.3	87.4	7	2.2	3.2	0.038	109
18.5	160 L	1LE0022-1DA43-3...	IE1	2935	60	36.5	0.86	89.3	89.9	89.1	7.6	2.5	3.4	0.046	122
22	180 M	1LE0022-1EA23-3...	IE1	2935	72	42.5	0.87	89.9	90.6	90	7.6	2.7	3.5	0.072	155
30	200 L	1LE0022-2AA43-3...	IE1	2950	97	58	0.87	90.7	90.8	89	7.5	2.5	3.2	0.13	219
37	200 L	1LE0022-2AA53-3...	IE1	2950	120	70	0.88	91.2	91.6	90.4	7.4	2.6	3.2	0.15	235
45	225 M	1LE0022-2BA23-3...	IE1	2960	145	85	0.88	91.7	91.9	90.5	7.6	2.8	3.3	0.24	295
55	250 M	1LE0022-2CA23-3...	IE1	2970	177	103	0.88	92.1	92.4	90.7	7.7	2.5	3.1	0.42	361
75	280 S	1LE0022-2DA03-3...	IE1	2970	241	141	0.87	92.7	92.6	91.1	6.7	2.7	3	0.75	484
90	280 M	1LE0022-2DA23-3...	IE1	2975	289	167	0.88	93	93.2	91.3	7.2	2.8	3	0.88	550
110	315 S	1LE0022-3AA03-3...	IE1	2982	353	199	0.9	93.3	93.1	91.2	7.5	2.2	3.1	1.4	715
132	315 M	1LE0022-3AA23-3...	IE1	2980	423	235	0.92	93.5	93.1	91.7	7.5	2.3	2.9	1.7	880
160	315 L	1LE0022-3AA53-3...	IE1	2982	513	280	0.92	93.8	93.6	92.5	7.6	2.5	2.8	1.9	930
185	315 L	1LE0022-3AA63-3...	IE1	2982	594	325	0.92	93.9	93.9	93.1	7.5	2.4	2.8	2.3	1080
200	315 L	1LE0022-3AA73-3...	IE1	2980	641	350	0.92	94	94.3	93.2	7.9	2.5	2.6	2.3	1090
220	355 M	1LE0022-3BA23-3...	IE1	2985	704	395	0.9	94.0	94.2	92.0	7	2	2.6	2.5	1410
250	355 M	1LE0022-3BA33-3...	IE1	2985	800	445	0.9	94.0	94.0	91.8	7.4	2.3	2.8	2.7	1480
280	355 L	1LE0022-3BA53-3...	IE1	2985	896	495	0.91	94.0	94.0	91.1	7	2.2	2.6	3	1550
315	355 L	1LE0022-3BA63-3...	IE1	2985	1008	560	0.91	94.0	94.0	91.8	7.4	2.5	2.8	3.3	1720

SIMOTICS Option Line – IE1

Cast-iron series			
Efficiency class	IE1		
Series	1LE0022		
No. of poles	2	4	6
Cooling	Self-ventilated (IC 411)		
Degree of protection	IP55		
Insulation	Thermal class 155 (F)		
Utilization	Thermal class 130 (B)		
Frame size	80 ... 355		
Rated output at 50 Hz	0.55 ... 315 kW		
Rated torque at 50 Hz	2.6 ... 2414 Nm		



The nominal torque of the motor is easy to calculate;
 Torque (Nm) =
 Power (kW) × 9550 / Speed (rpm).

Electrical data – 1LE0 – IE1 – 4-pole (IE1 cast iron) 1500 rpm 4-pole, 380 VΔ 50 Hz															
Rated output kW	Frame size	Article number	IE class	Rated speed rpm	Rated torque Nm	Rated current A	Rated power factor	Efficiency at			Starting current	Starting torque	Break-down torque	Moment of inertia kgm ²	Net weight (IM B3) kg
								100% load %	75% load %	50% load %					
220 VΔ / 380 VY															
0.55	80 M	1LE0022-0DB22-1...	IE1	1415	3.7	1.47	0.81	70.0	70.5	67.4	4.5	2	2.6	0.0021	15.5
0.75	80 M	1LE0022-0DB32-1...	IE1	1415	5.1	1.95	0.81	72.1	73.7	71.8	4.8	2	2.6	0.0027	17.5
1.1	90 S	1LE0022-0EB02-1...	IE1	1425	7.4	2.80	0.8	75	77.3	74.3	5.4	2	2.6	0.0041	20
1.5	90 L	1LE0022-0EB42-1...	IE1	1425	10	3.65	0.81	77.2	77.3	75.1	5.6	2	2.5	0.0047	24
2.2	100 L	1LE0022-1AB42-1...	IE1	1430	14.8	5.1	0.82	79.7	80.7	78.7	5.8	2.4	2.9	0.0081	33
3	100 L	1LE0022-1AB52-1...	IE1	1430	20.2	6.7	0.83	81.5	83.1	81.5	6.5	2.8	3.1	0.01	35
380 VΔ / 660 VY															
4	112 M	1LE0022-1BB23-3...	IE1	1445	26.4	9.3	0.79	83.1	83.3	81.5	7.4	2.8	3.3	0.011	43
5.5	132 S	1LE0022-1CB03-3...	IE1	1450	36.2	12.0	0.82	84.7	85.5	84.3	6.5	2	3.1	0.021	62
7.5	132 M	1LE0022-1CB23-3...	IE1	1435	50	15.8	0.84	86	87.2	87.2	6.4	2.3	3.1	0.029	74
11	160 M	1LE0022-1DB23-3...	IE1	1460	72	22.5	0.84	87.6	88.5	87.8	6.9	2.2	3.3	0.051	106
15	160 L	1LE0022-1DB43-3...	IE1	1465	98	30.5	0.84	88.7	89.4	88.6	7.8	2.7	3.8	0.066	124
18.5	180 M	1LE0022-1EB23-3...	IE1	1470	120	37.5	0.84	89.3	90.3	89.9	7.8	2.7	3.5	0.13	167
22	180 L	1LE0022-1EB43-3...	IE1	1465	143	43.5	0.85	89.9	90.9	89.9	7.8	2.4	3.2	0.14	183
30	200 L	1LE0022-2AB43-3...	IE1	1470	195	59	0.85	90.7	91.6	90.5	7.4	2.4	3.1	0.22	231
37	225 S	1LE0022-2BB03-3...	IE1	1470	240	72	0.86	91.2	91.8	91	7.3	2.3	2.8	0.45	287
45	225 M	1LE0022-2BB23-3...	IE1	1475	292	86	0.87	91.7	92.4	92	7.8	2.9	3.3	0.51	314
55	250 M	1LE0022-2CB23-3...	IE1	1478	356	106	0.86	92.1	92.8	92	7.6	3	2.8	0.8	394
75	280 S	1LE0022-2DB03-3...	IE1	1480	484	140	0.88	92.7	93.3	92.2	7.2	2.6	2.8	1.4	540
90	280 M	1LE0022-2DB23-3...	IE1	1485	579	167	0.88	93	93.5	92.2	7.8	2.7	2.8	1.5	595
110	315 S	1LE0022-3AB03-3...	IE1	1490	706	211	0.85	93.3	93.4	92.5	8.6	2.8	3.1	2.2	720
132	315 M	1LE0022-3AB23-3...	IE1	1488	848	245	0.88	93.5	93.8	93.4	7.3	2.5	2.7	2.5	850
160	315 L	1LE0022-3AB53-3...	IE1	1488	1030	300	0.87	93.8	94	93.6	7.4	3	2.9	3	930
185	315 L	1LE0022-3AB63-3...	IE1	1490	1185	340	0.88	93.9	94.1	93.6	7.6	3	2.9	3.6	1040
200	315 L	1LE0022-3AB73-3...	IE1	1488	1285	365	0.88	94	94.3	94.1	7.4	3	3	3.7	1050
220	355 M	1LE0022-3BB23-3...	IE1	1490	1411	400	0.89	94.0	94.1	92.1	6.9	1.7	2.5	4.9	1580
250	355 M	1LE0022-3BB33-3...	IE1	1490	1604	455	0.89	94.0	94.0	92.4	6.9	1.8	2.5	5	1640
280	355 L	1LE0022-3BB53-3...	IE1	1490	1795	510	0.89	94.0	94.0	92.2	7	1.9	2.7	5.3	1690
315	355 L	1LE0022-3BB63-3...	IE1	1490	2019	570	0.89	94.0	94.1	92.4	7	1.9	2.7	5.7	1790

SIMOTICS Option Line – IE1

Cast-iron series	
Efficiency class	IE1
Series	1LE0022
No. of poles	2 4 6
Cooling	Self-ventilated (IC 411)
Degree of protection	IP55
Insulation	Thermal class 155 (F)
Utilization	Thermal class 130 (B)
Frame size	80 ... 355
Rated output at 50 Hz	0.55 ... 315 kW
Rated torque at 50 Hz	2.6 ... 2414 Nm



The nominal torque of the motor is easy to calculate;
 Torque (Nm) =
 Power (kW) × 9550 / Speed (rpm).

Electrical data – 1LE0 – IE1 – 6-pole (IE1 cast iron) 1000 rpm 6-pole, 380 VΔ 50 Hz																
Rated output kW	Frame size	Article number	IE class	Rated speed rpm	Rated torque Nm	Rated current A	Rated power factor	Efficiency at			Starting current	Starting torque	Break-down torque	Moment of inertia kgm ²	Net weight (IM B3) kg	
								100% load %	75% load %	50% load %						
220 VΔ / 380 VY																
0.55	80 M	1LE0022-0DC32-1...	IE1	910	5.8	1.67	0.74	67.5	68.7	65.6	3.8	2.1	2.4	0.0028	17	
0.75	90 S	1LE0022-0EC02-1...	IE1	930	7.7	2.20	0.74	70	71.5	68.9	3.9	2	2.5	0.0038	21	
1.1	90 L	1LE0022-0EC42-1...	IE1	935	11.3	3.15	0.73	72.9	74	71.8	4.4	2.2	2.7	0.0046	26	
1.5	100 L	1LE0022-1AC42-1...	IE1	940	15.4	4.00	0.76	75.2	77.2	74.7	4.6	2.1	2.6	0.0086	34	
2.2	112 M	1LE0022-1BC22-1...	IE1	940	22.3	5.7	0.75	77.7	79.2	78.1	5.2	2.4	3	0.012	42	
3	132 S	1LE0022-1CC02-1...	IE1	955	30	7.8	0.73	79.7	80.9	79.3	5.2	2	2.8	0.019	54	
380 VΔ / 660 VY																
4	132 M	1LE0022-1CC23-3...	IE1	950	40	10.2	0.73	81.4	82.2	79.4	5.6	2.1	2.9	0.024	67	
5.5	132 M	1LE0022-1CC33-3...	IE1	955	55	13.6	0.74	83.1	84.2	83	6	2.3	3.2	0.031	76	
7.5	160 M	1LE0022-1DC23-3...	IE1	980	74	17.7	0.76	84.7	85.4	84.5	5.8	2	2.9	0.1069	107	
11	160 L	1LE0022-1DC43-3...	IE1	980	109	25.5	0.76	86.4	87	86	6.6	2.2	3.1	0.14	127	
15	180 L	1LE0022-1EC43-3...	IE1	970	148	33.5	0.78	87.7	88.7	88.4	6.5	2.3	3	0.18	165	
18.5	200 L	1LE0022-2AC43-3...	IE1	975	182.1	38.5	0.82	88.6	90	90.1	5.8	2.2	2.8	0.27	225	
22	200 L	1LE0022-2AC53-3...	IE1	975	215	45.5	0.82	89.2	90.5	90.5	6.5	2.3	2.8	0.32	231	
30	225 M	1LE0022-2BC23-3...	IE1	978	293	61	0.83	90.2	91.4	90.5	6.7	2.4	2.8	0.62	298	
37	250 M	1LE0022-2CC23-3...	IE1	982	360	75	0.83	90.8	91.5	91.2	7.5	3	2.8	0.91	376	
45	280 S	1LE0022-2DC03-3...	IE1	985	437	88	0.85	91.4	92.4	92.3	7.1	2.5	2.8	1.2	456	
55	280 M	1LE0022-2DC23-3...	IE1	988	532	107	0.85	91.9	92.6	92.4	7.5	2.4	2.7	1.5	545	
75	315 S	1LE0022-3AC03-3...	IE1	988	725	145	0.85	92.6	93	92.4	7.5	2.4	3	2.3	680	
90	315 M	1LE0022-3AC23-3...	IE1	986	872	173	0.85	92.9	93.4	93.2	7	2.3	2.8	2.8	835	
110	315 L	1LE0022-3AC53-3...	IE1	986	1066	210	0.86	93.3	93.9	93.8	6.5	2.2	2.7	3.9	975	
132	315 L	1LE0022-3AC63-3...	IE1	988	1278	250	0.86	93.5	94.2	93.6	7.8	2.2	2.4	4.3	1030	
160	355 M	1LE0022-3BC23-3...	IE1	989	1542	300	0.87	93.8	93.9	91.7	7	2.4	2.2	8.9	1630	
185	355 M	1LE0022-3BC33-3...	IE1	989	1783	340	0.87	93.9	94.0	92.0	7.1	2.6	2.6	9.4	1760	
200	355 M	1LE0022-3BC43-3...	IE1	989	1930	375	0.87	94.0	94.0	92.7	7.1	2.6	2.6	10.5	1760	
220	355 L	1LE0022-3BC53-3...	IE1	989	2121	410	0.87	94.0	94.0	91.9	7.6	2.6	2.6	11.5	1870	
250	355 L	1LE0022-3BC63-3...	IE1	989	2408	465	0.87	94.0	94.0	92.7	7.8	2.8	2.7	12.9	1950	

SIMOTICS Option Line – IE2

Cast-iron series	
Efficiency class	IE2
Series	1LE0021
No. of poles	2 4 6
Cooling	Self-ventilated (IC 411)
Degree of protection	IP55
Insulation	Thermal class 155 (F)
Utilization	Thermal class 130 (B)
Frame size	80 ... 355
Rated output at 50 Hz	0.55 ... 315 kW
Rated torque at 50 Hz	2.6 ... 2412 Nm



TIP
 The nominal torque of the motor is easy to calculate;
 Torque (Nm) =
 Power (kW) × 9550 / Speed (rpm).

Electrical data – 1LE0 – IE2 – 2-pole		(IE2 cast iron) 3000 rpm 2-pole, 400 V 50 Hz														
Rated output		Frame size	Article number	IE class	Rated speed	Rated torque	Rated current	Rated power factor	Efficiency at			Starting current	Starting torque	Break-down torque	Moment of inertia	Net weight (IM B3)
50 Hz kW	60 Hz kW								100% load %	75% load %	50% load %					
230 VΔ / 400 VY																
0.75	0.86	80 M	1LE0021-0DA22-2...	IE2	2795	2.6	1.67	0.84	77.4	78.5	78.5	5.6	2.4	2.4	0.0008	15
1.1	1.3	80 M	1LE0021-0DA32-2...	IE2	2835	3.7	2.4	0.84	79.6	80.6	77.4	6	2.8	3.2	0.0012	16
1.5	1.75	90 S	1LE0021-0EA02-2...	IE2	2890	5	3.2	0.84	81.3	81.7	78	6.5	2.4	3.1	0.0021	20
2.2	2.55	90 L	1LE0021-0EA42-2...	IE2	2890	7.3	4.55	0.85	83.2	83.7	80.8	7.2	2.6	3.5	0.0026	23
3	3.45	100 L	1LE0021-1AA42-2...	IE2	2885	9.9	6.1	0.84	84.6	85.1	84.1	7.5	4	4.5	0.0036	33
400 VΔ / 690 VY																
4	4.6	112 M	1LE0021-1BA23-4...	IE2	2930	13	7.8	0.86	85.8	86.6	84.7	7.5	2.2	2.9	0.0064	39
5.5	6.3	132 S	1LE0021-1CA03-4...	IE2	2930	17.9	10.5	0.87	87	87.6	86.9	7.5	2.2	2.9	0.014	54
7.5	8.6	132 S	1LE0021-1CA13-4...	IE2	2930	24.4	13.8	0.89	88.1	88.8	88.5	7.5	2.3	2.9	0.017	63
11	12.6	160 M	1LE0021-1DA23-4...	IE2	2935	35.8	20.5	0.86	89.4	90.1	89.3	7.5	2.2	2.9	0.031	99
15	17.3	160 M	1LE0021-1DA33-4...	IE2	2935	48.8	28	0.86	90.3	91	90.5	7.5	2.4	3.2	0.038	109
18.5	21.3	160 L	1LE0021-1DA43-4...	IE2	2935	60.2	33	0.89	90.9	91.7	91.5	7.5	2.4	3.2	0.046	123
22	24.5	180 M	1LE0021-1EA23-4...	IE2	2935	71.6	40	0.87	91.3	91.8	91.1	7.6	2.5	3.2	0.072	155
30	33.5	200 L	1LE0021-2AA43-4...	IE2	2955	97	55	0.86	92	92.3	91.5	7.5	2.5	3.2	0.13	219
37	41.5	200 L	1LE0021-2AA53-4...	IE2	2955	120	66	0.88	92.5	92.8	92.3	7.5	2.5	3.2	0.15	235
45	51	225 M	1LE0021-2BA23-4...	IE2	2965	145	80	0.88	92.9	93.1	92.5	7.9	2.5	3.1	0.24	296
55	62	250 M	1LE0021-2CA23-4...	IE2	2970	177	97	0.88	93.2	93.2	91.8	7.5	2.5	3	0.42	363
75	84	280 S	1LE0021-2DA03-4...	IE2	2975	241	133	0.87	93.8	93.8	92.7	7.5	2.8	3	0.75	487
90	101	280 M	1LE0021-2DA23-4...	IE2	2978	289	159	0.87	94.1	94.1	92.9	7.5	3	3.1	0.88	550
110	123	315 S	1LE0021-3AA03-4...	IE2	2982	352	187	0.9	94.3	94.3	93.3	7.5	2.2	2.6	1.4	715
132	148	315 M	1LE0021-3AA23-4...	IE2	2982	423	220	0.91	94.6	94.6	93.9	7.5	2.3	2.9	1.7	880
160	180	315 L	1LE0021-3AA53-4...	IE2	2982	512	265	0.92	94.8	95.1	94.1	7.5	2.5	2.8	1.9	930
185	207	315 L	1LE0021-3AA63-4...	IE2	2982	592	305	0.92	95	95.3	94.2	7.5	2.5	2.8	2.3	1080
200	224	315 L	1LE0021-3AA73-4...	IE2	2982	641	330	0.92	95	95.3	94.4	7.5	2.5	2.8	2.3	1090
220	246	355 M	1LE0021-3BA23-4...	IE2	2985	705	370	0.9	95	95	92.8	7.1	2	2.2	2.5	1410
250	280	355 M	1LE0021-3BA33-4...	IE2	2985	801	420	0.9	95	95	93	7.1	2	2.2	2.7	1480
280	314	355 L	1LE0021-3BA53-4...	IE2	2985	897	475	0.9	95	95.1	93	7.1	2	2.2	3	1550
315	353	355 L	1LE0021-3BA63-4...	IE2	2985	1009	530	0.9	95	95.1	93.1	7.1	2	2.3	3.3	1720

SIMOTICS Option Line – IE2

Cast-iron series	
Efficiency class	IE2
Series	1LE0021
No. of poles	2 4 6
Cooling	Self-ventilated (IC 411)
Degree of protection	IP55
Insulation	Thermal class 155 (F)
Utilization	Thermal class 130 (B)
Frame size	80 ... 355
Rated output at 50 Hz	0.55 ... 315 kW
Rated torque at 50 Hz	2.6 ... 2412 Nm



The nominal torque of the motor is easy to calculate;
 Torque (Nm) =
 Power (kW) × 9550 / Speed (rpm).

Electrical data – 1LE0 – IE2 – 4-pole		(IE2 cast iron) 1500 rpm 4-pole, 400 V 50 Hz														
Rated output		Frame size	Article number	IE class	Rated speed	Rated torque	Rated current	Rated power factor	Efficiency at			Starting current	Starting torque	Break-down torque	Moment of inertia	Net weight (IM B3)
50 Hz	60 Hz								100% load	75% load	50% load					
kW	kW				rpm	Nm	A	%	%	%				kgm ²	kg	
230 VΔ / 400 VY																
0.55	0.63	80 M	1LE0021-0DB22-2...	IE2	1425	3.7	1.32	0.78	77.1	77.8	73.2	6	2	2.7	0.0021	15.5
0.75	0.86	80 M	1LE0021-0DB32-2...	IE2	1440	5	1.82	0.75	79.6	79.6	76.8	6.5	2.8	3.5	0.0027	17.5
1.1	1.3	90 S	1LE0021-0EB02-2...	IE2	1440	7.3	2.65	0.75	81.4	81.4	77.6	7	2.8	3.5	0.0041	21
1.5	1.75	90 L	1LE0021-0EB42-2...	IE2	1435	9.9	3.45	0.76	82.8	82.8	80.2	7	3	3.8	0.0047	24
2.2	2.55	100 L	1LE0021-1AB42-2...	IE2	1435	14.6	4.8	0.79	84.3	85	83.1	7	3	3.2	0.0081	33
3	3.45	100 L	1LE0021-1AB52-2...	IE2	1435	20	6.4	0.79	85.5	86.3	84.2	7	3	3.2	0.01	35
400 VΔ / 690 VY																
4	4.6	112 M	1LE0021-1BB23-4...	IE2	1445	26.4	8.5	0.79	86.6	87.1	85.8	7.1	2.7	3.1	0.011	43
5.5	6.3	132 S	1LE0021-1CB03-4...	IE2	1460	36	11.5	0.79	87.7	88.2	86.9	7.5	2.5	3.1	0.021	62
7.5	8.6	132 M	1LE0021-1CB23-4...	IE2	1460	49.1	14.9	0.82	88.7	89.4	88.8	7.7	2.7	3.2	0.029	74
11	12.6	160 M	1LE0021-1DB23-4...	IE2	1465	71.7	21	0.84	89.8	90.4	90.1	7.5	2.5	3.1	0.051	106
15	17.3	160 L	1LE0021-1DB43-4...	IE2	1465	97.8	28	0.85	90.6	91.3	90.6	7.8	2.7	3.2	0.066	124
18.5	21.3	180 M	1LE0021-1EB23-4...	IE2	1465	121	34.5	0.85	91.2	91.8	91.8	7.3	2.5	3.2	0.13	168
22	24.5	180 L	1LE0021-1EB43-4...	IE2	1465	143	41	0.85	91.6	92.3	92.7	7.3	2.4	3.2	0.14	183
30	33.5	200 L	1LE0021-2AB43-4...	IE2	1470	195	55	0.85	92.3	92.9	92.9	7.3	2.7	3.2	0.22	232
37	41.5	225 S	1LE0021-2BB03-4...	IE2	1475	240	67	0.86	92.7	93.2	92.9	7.3	2.7	3.2	0.45	289
45	51	225 M	1LE0021-2BB23-4...	IE2	1475	291	80	0.87	93.1	93.5	93.9	7.3	2.7	3.2	0.51	314
55	62	250 M	1LE0021-2CB23-4...	IE2	1480	355	99	0.86	93.5	93.9	93.3	7.5	3.1	3.5	0.8	395
75	84	280 S	1LE0021-2DB03-4...	IE2	1485	482	132	0.87	94	94.3	93.9	7.5	2.7	3.1	1.4	540
90	101	280 M	1LE0021-2DB23-4...	IE2	1485	579	159	0.87	94.2	94.3	94.2	7.5	2.7	3.1	1.5	595
110	123	315 S	1LE0021-3AB03-4...	IE2	1488	706	195	0.86	94.5	94.5	93.9	7.3	2.8	2.9	2.2	720
132	148	315 M	1LE0021-3AB23-4...	IE2	1486	848	230	0.88	94.7	94.7	95	7.3	2.5	2.7	2.5	850
160	180	315 L	1LE0021-3AB53-4...	IE2	1488	1027	275	0.88	94.9	94.9	95.1	7.4	3	2.9	3	930
185	207	315 L	1LE0021-3AB63-4...	IE2	1488	1187	320	0.88	95.1	95.1	95	7.4	3	3	3.6	1040
200	224	315 L	1LE0021-3AB73-4...	IE2	1488	1284	345	0.88	95.1	95.1	95.1	7.4	3	3	3.7	1050
220	246	355 M	1LE0021-3BB23-4...	IE2	1490	1410	370	0.9	95.1	95.2	93.3	6.9	2	2.2	4.9	1580
250	280	355 M	1LE0021-3BB33-4...	IE2	1490	1602	420	0.9	95.1	95.2	93.8	6.9	2	2.2	5	1640
280	314	355 L	1LE0021-3BB53-4...	IE2	1490	1795	470	0.9	95.1	95.2	93.8	6.9	2	2.2	5.3	1690
315	353	355 L	1LE0021-3BB63-4...	IE2	1490	2019	530	0.9	95.1	95.2	93.8	6.9	2	2.2	5.7	1790

SIMOTICS Option Line – IE2

Cast-iron series	
Efficiency class	IE2
Series	1LE0021
No. of poles	2 4 6
Cooling	Self-ventilated (IC 411)
Degree of protection	IP55
Insulation	Thermal class 155 (F)
Utilization	Thermal class 130 (B)
Frame size	80 ... 355
Rated output at 50 Hz	0.55 ... 315 kW
Rated torque at 50 Hz	2.6 ... 2412 Nm

TIP

The nominal torque of the motor is easy to calculate;
 Torque (Nm) =
 Power (kW) × 9550 / Speed (rpm).

Electrical data – 1LE0 – IE2 – 6-pole		(IE2 cast iron) 1000 rpm 6-pole, 400 V 50 Hz														
Rated output 50 Hz kW	Rated output 60 Hz kW	Frame size	Article number	IE class	Rated speed rpm	Rated torque Nm	Rated current A	Rated power factor	Efficiency at			Starting current	Starting torque	Break- down torque	Moment of inertia kgm ²	Net weight (IM B3) kg
									100% load %	75% load %	50% load %					
230 VΔ / 400 VY																
0.55	0.63	80 M	1LE0021-0DC32-2...	IE2	895	5.9	1.53	0.71	73.1	74.1	70.6	3.8	2.1	2.4	0.0028	17
0.75	0.86	90 S	1LE0021-0EC02-2...	IE2	935	7.7	2	0.71	75.9	76.5	72.7	3.9	2	2.5	0.0038	21
1.1	1.3	90 L	1LE0021-0EC42-2...	IE2	945	11.1	2.85	0.71	78.1	78.1	75.7	4.4	2.2	2.7	0.0046	26
1.5	1.75	100 L	1LE0021-1AC42-2...	IE2	945	15.2	3.7	0.74	79.8	80.1	78.2	4.6	2.1	2.6	0.0086	34
2.2	2.55	112 M	1LE0021-1BC22-2...	IE2	950	22.1	5.4	0.73	81.8	82.5	81	5.2	2.4	3	0.012	42
3	3.45	132 S	1LE0021-1CC02-2...	IE2	960	29.8	7.2	0.73	83.3	84.3	83.4	5.2	2	2.8	0.019	54
400 VΔ / 690 VY																
4	4.6	132 M	1LE0021-1CC23-4...	IE2	960	39.8	9.3	0.73	84.6	85.4	84.5	5.6	2.1	2.9	0.024	67
5.5	6.3	132 M	1LE0021-1CC33-4...	IE2	960	54.7	12.4	0.75	86	86.6	85.7	6	2.3	3.2	0.031	76
7.5	8.6	160 M	1LE0021-1DC23-4...	IE2	975	73.5	16.2	0.77	87.2	87.9	87.2	5.8	2	2.9	0.1069	107
11	12.6	160 L	1LE0021-1DC43-4...	IE2	975	108	23	0.78	88.7	89.4	89.5	6.6	2.2	3.1	0.14	127
15	17.3	180 L	1LE0021-1EC43-4...	IE2	975	147	31	0.78	89.7	90.4	89.9	6.5	2.3	3	0.18	165
18.5	21.3	200 L	1LE0021-2AC43-4...	IE2	975	181	36.5	0.81	90.4	91	91.8	5.8	2.2	2.8	0.27	226
22	24.5	200 L	1LE0021-2AC53-4...	IE2	975	215	43	0.82	90.9	91.4	91.9	6.5	2.3	2.8	0.32	232
30	33.5	225 M	1LE0021-2BC23-4...	IE2	980	292	57	0.83	91.7	92.3	92.7	6.7	2.4	2.8	0.62	300
37	41.5	250 M	1LE0021-2CC23-4...	IE2	982	360	69	0.83	92.2	92.8	92.3	7.5	3	2.8	0.91	379
45	51	280 S	1LE0021-2DC03-4...	IE2	985	436	83	0.85	92.7	93.3	93.5	7.1	2.5	2.8	1.2	457
55	62	280 M	1LE0021-2DC23-4...	IE2	986	533	101	0.85	93.1	93.7	93.6	7.5	2.4	2.7	1.5	545
75	84	315 S	1LE0021-3AC03-4...	IE2	986	726	136	0.85	93.7	94.3	93.8	7.5	2.4	3	2.3	680
90	101	315 M	1LE0021-3AC23-4...	IE2	986	872	163	0.85	94	94.5	94.4	7	2.3	2.8	2.8	835
110	123	315 L	1LE0021-3AC53-4...	IE2	988	1063	195	0.86	94.3	94.7	94.6	6.5	2.2	2.7	3.9	975
132	148	315 L	1LE0021-3AC63-4...	IE2	988	1276	230	0.86	94.6	95	94.9	7.8	2.2	2.4	4.3	1030
160	180	355 M	1LE0021-3BC23-4...	IE2	991	1543	280	0.87	94.8	95.1	93.5	6.5	2	2.1	8.9	1630
185	207	355 M	1LE0021-3BC33-4...	IE2	991	1785	325	0.87	95	95.3	93.5	6.5	2	2.1	9.4	1760
200	224	355 M	1LE0021-3BC43-4...	IE2	991	1929	350	0.87	95	95.3	93.6	6.5	2	2.1	10.5	1760
220	246	355 L	1LE0021-3BC53-4...	IE2	991	2122	385	0.87	95	95.3	93.5	6.5	2	2.1	11.5	1870
250	280	355 L	1LE0021-3BC63-4...	IE2	991	2412	435	0.87	95	95.3	93.5	6.5	2	2.1	12.9	1950

SIMOTICS Option Line – IE2

Cast-iron series			
Efficiency class	IE2		
Series	1LE0021		
No. of poles	2	4	6
Cooling	Self-ventilated (IC 411)		
Degree of protection	IP55		
Insulation	Thermal class 155 (F)		
Utilization	Thermal class 130 (B)		
Frame size	80 ... 355		
Rated output at 50 Hz	0.55 ... 315 kW		
Rated torque at 50 Hz	2.6 ... 2412 Nm		



TIP
 The nominal torque of the motor is easy to calculate;
 Torque (Nm) =
 Power (kW) × 9550 / Speed (rpm).

Electrical data – 1LE0 – IE2 – 2-pole (IE2 cast iron) 3000 rpm 2-pole, 380 VΔ 50 Hz															
Rated output kW	Frame size	Article number	IE class	Rated speed rpm	Rated torque Nm	Rated current A	Rated power factor	Efficiency at			Starting current	Starting torque	Break-down torque	Moment of inertia kgm ²	Net weight (IM B3) kg
								100% load %	75% load %	50% load %					
220 VΔ / 380 VY															
0.75	80 M	1LE0021-0DA22-1...	IE2	2795	2.6	1.75	0.84	77.4	78.5	78.5	5.6	2.4	2.4	0.0008	15.5
1.1	80 M	1LE0021-0DA32-1...	IE2	2835	3.7	2.50	0.84	79.6	80.6	77.4	6	2.8	3.2	0.0012	17.5
1.5	90 S	1LE0021-0EA02-1...	IE2	2890	5	3.35	0.84	81.3	81.7	78	6.5	2.4	3.1	0.0021	23
2.2	90 L	1LE0021-0EA42-1...	IE2	2890	7.3	4.75	0.85	83.2	83.7	80.8	7.2	2.6	3.5	0.0026	26
3	100 L	1LE0021-1AA42-1...	IE2	2885	9.9	6.4	0.84	84.6	85.1	84.1	7.5	4	4.5	0.0036	34
380 VΔ / 660 VY															
4	112 M	1LE0021-1BA23-3...	IE2	2930	13	8.2	0.86	85.8	86.6	84.7	7.5	2.2	2.9	0.0064	40
5.5	132 S	1LE0021-1CA03-3...	IE2	2930	17.9	11.0	0.87	87	87.6	86.9	7.5	2.2	2.9	0.014	56
7.5	132 S	1LE0021-1CA13-3...	IE2	2930	24.4	14.5	0.89	88.1	88.8	88.5	7.5	2.3	2.9	0.017	62
11	160 M	1LE0021-1DA23-3...	IE2	2935	35.8	21.5	0.86	89.4	90.1	89.3	7.5	2.2	2.9	0.031	96
15	160 M	1LE0021-1DA33-3...	IE2	2935	48.8	39.5	0.86	90.3	91	90.5	7.5	2.4	3.2	0.038	106
18.5	160 L	1LE0021-1DA43-3...	IE2	2935	60.2	34.5	0.89	90.9	91.7	91.5	7.5	2.4	3.2	0.046	125
22	180 M	1LE0021-1EA23-3...	IE2	2935	71.6	42.0	0.87	91.3	91.8	91.1	7.6	2.5	3.2	0.072	152
30	200 L	1LE0021-2AA43-3...	IE2	2955	97	58	0.86	92	92.3	91.5	7.5	2.5	3.2	0.13	229
37	200 L	1LE0021-2AA53-3...	IE2	2955	120	69	0.88	92.5	92.8	92.3	7.5	2.5	3.2	0.15	245
45	225 M	1LE0021-2BA23-3...	IE2	2965	145	84	0.88	92.9	93.1	92.5	7.9	2.5	3.1	0.24	307
55	250 M	1LE0021-2CA23-3...	IE2	2970	177	102	0.88	93.2	93.2	91.8	7.5	2.5	3	0.42	378
75	280 S	1LE0021-2DA03-3...	IE2	2975	241	140	0.87	93.8	93.8	92.7	7.5	2.8	3	0.75	550
90	280 M	1LE0021-2DA23-3...	IE2	2978	289	167	0.87	94.1	94.1	92.9	7.5	3	3.1	0.88	570
110	315 S	1LE0021-3AA03-3...	IE2	2982	352	197	0.9	94.3	94.3	93.3	7.5	2.2	2.6	1.4	740
132	315 M	1LE0021-3AA23-3...	IE2	2982	423	235	0.91	94.6	94.6	93.9	7.5	2.3	2.9	1.7	855
160	315 L	1LE0021-3AA53-3...	IE2	2982	512	280	0.92	94.8	95.1	94.1	7.5	2.5	2.8	1.9	970
185	315 L	1LE0021-3AA63-3...	IE2	2982	592	320	0.92	95	95.3	94.2	7.5	2.5	2.8	2.3	1080
200	315 L	1LE0021-3AA73-3...	IE2	2982	641	350	0.92	95	95.3	94.4	7.5	2.5	2.8	2.3	1090
220	355 M	1LE0021-3BA23-3...	IE2	2985	705	390	0.9	95	95	92.8	7.1	2	2.2	2.9	1600
250	355 M	1LE0021-3BA33-3...	IE2	2985	801	445	0.9	95	95	93	7.1	2	2.2	3	1650
280	355 L	1LE0021-3BA53-3...	IE2	2985	897	490	0.9	95	95.1	93	7.1	2	2.2	3.5	1830
315	355 L	1LE0021-3BA63-3...	IE2	2985	1009	550	0.9	95	95.1	93.1	7.1	2	2.3	3.5	1720

SIMOTICS Option Line – IE2

Cast-iron series			
Efficiency class	IE2		
Series	1LE0021		
No. of poles	2	4	6
Cooling	Self-ventilated (IC 411)		
Degree of protection	IP55		
Insulation	Thermal class 155 (F)		
Utilization	Thermal class 130 (B)		
Frame size	80 ... 355		
Rated output at 50 Hz	0.55 ... 315 kW		
Rated torque at 50 Hz	2.6 ... 2412 Nm		



TIP
 The nominal torque of the motor is easy to calculate;
 Torque (Nm) =
 Power (kW) × 9550 / Speed (rpm).

Electrical data – 1LE0 – IE2 – 4-pole (IE2 cast iron) 1500 rpm 4-pole, 380 VΔ 50 Hz															
Rated output kW	Frame size	Article number	IE class	Rated speed rpm	Rated torque Nm	Rated current A	Rated power factor	Efficiency at			Starting current	Starting torque	Break-down torque	Moment of inertia kgm ²	Net weight (IM B3) kg
								100% load %	75% load %	50% load %					
220 VΔ / 380 VY															
0.55	80 M	1LE0021-0DB22-1...	IE2	1425	3.7	1.39	0.78	77.1	77.8	73.2	6	2	2.7	0.0021	17.5
0.75	80 M	1LE0021-0DB32-1...	IE2	1440	5	1.90	0.75	79.6	79.6	76.8	6.5	2.8	3.5	0.0027	19
1.1	90 S	1LE0021-0EB02-1...	IE2	1440	7.3	2.75	0.75	81.4	81.4	77.6	7	2.8	3.5	0.0041	24
1.5	90 L	1LE0021-0EB42-1...	IE2	1435	9.9	3.60	0.76	82.8	82.8	80.2	7	3	3.8	0.0047	27
2.2	100 L	1LE0021-1AB42-1...	IE2	1435	14.6	5.0	0.79	84.3	85	83.1	7	3	3.2	0.0081	33
3	100 L	1LE0021-1AB52-1...	IE2	1435	20	6.7	0.79	85.5	86.3	84.2	7	3	3.2	0.01	37
380 VΔ / 660 VY															
4	112 M	1LE0021-1BB23-3...	IE2	1445	26.4	8.9	0.79	86.6	87.1	85.8	7.1	2.7	3.1	0.011	45
5.5	132 S	1LE0021-1CB03-3...	IE2	1460	36	12.1	0.79	87.7	88.2	86.9	7.5	2.5	3.1	0.021	61
7.5	132 M	1LE0021-1CB23-3...	IE2	1460	49.1	15.7	0.82	88.7	89.4	88.8	7.7	2.7	3.2	0.029	73
11	160 M	1LE0021-1DB23-3...	IE2	1465	71.7	22.0	0.84	89.8	90.4	90.1	7.5	2.5	3.1	0.051	103
15	160 L	1LE0021-1DB43-3...	IE2	1465	97.8	29.5	0.85	90.6	91.3	90.6	7.8	2.7	3.2	0.066	130
18.5	180 M	1LE0021-1EB23-3...	IE2	1465	121	36.5	0.85	91.2	91.8	91.8	7.3	2.5	3.2	0.13	165
22	180 L	1LE0021-1EB43-3...	IE2	1465	143	43.0	0.85	91.6	92.3	92.7	7.3	2.4	3.2	0.14	180
30	200 L	1LE0021-2AB43-3...	IE2	1470	195	58	0.85	92.3	92.9	92.9	7.3	2.7	3.2	0.22	238
37	225 S	1LE0021-2BB03-3...	IE2	1475	240	71	0.86	92.7	93.2	92.9	7.3	2.7	3.2	0.45	298
45	225 M	1LE0021-2BB23-3...	IE2	1475	291	84	0.87	93.1	93.5	93.9	7.3	2.7	3.2	0.51	322
55	250 M	1LE0021-2CB23-3...	IE2	1480	355	104	0.86	93.5	93.9	93.3	7.5	3.1	3.5	0.8	365
75	280 S	1LE0021-2DB03-3...	IE2	1485	482	139	0.87	94	94.3	93.9	7.5	2.7	3.1	1.4	555
90	280 M	1LE0021-2DB23-3...	IE2	1485	579	167	0.87	94.2	94.3	94.2	7.5	2.7	3.1	1.5	610
110	315 S	1LE0021-3AB03-3...	IE2	1488	706	205	0.86	94.5	94.5	93.9	7.3	2.8	2.9	2.2	750
132	315 M	1LE0021-3AB23-3...	IE2	1486	848	240	0.88	94.7	94.7	95	7.3	2.5	2.7	2.5	875
160	315 L	1LE0021-3AB53-3...	IE2	1488	1027	290	0.88	94.9	94.9	95.1	7.4	3	2.9	3	960
185	315 L	1LE0021-3AB63-3...	IE2	1488	1187	335	0.88	95.1	95.1	95	7.4	3	3	3.6	1070
200	315 L	1LE0021-3AB73-3...	IE2	1488	1284	365	0.88	95.1	95.1	95.1	7.4	3	3	3.7	1080
220	355 M	1LE0021-3BB23-3...	IE2	1490	1410	395	0.9	95.1	95.2	93.3	6.9	2	2.2	6.6	1630
250	355 M	1LE0021-3BB33-3...	IE2	1490	1602	450	0.9	95.1	95.2	93.8	6.9	2	2.2	6.9	1680
280	355 L	1LE0021-3BB53-3...	IE2	1490	1795	500	0.9	95.1	95.2	93.8	6.9	2	2.2	7.7	1690
315	355 L	1LE0021-3BB63-3...	IE2	1490	2019	570	0.9	95.1	95.2	93.8	6.9	2	2.2	8.5	1640

SIMOTICS Option Line – IE2

Cast-iron series			
Efficiency class	IE2		
Series	1LE0021		
No. of poles	2	4	6
Cooling	Self-ventilated (IC 411)		
Degree of protection	IP55		
Insulation	Thermal class 155 (F)		
Utilization	Thermal class 130 (B)		
Frame size	80 ... 355		
Rated output at 50 Hz	0.55 ... 315 kW		
Rated torque at 50 Hz	2.6 ... 2412 Nm		



TIP

The nominal torque of the motor is easy to calculate;
 Torque (Nm) =
 Power (kW) × 9550 / Speed (rpm).

Electrical data – 1LE0 – IE2 – 6-pole (IE2 cast iron) 1000 rpm 6-pole, 380 VΔ 50 Hz															
Rated output kW	Frame size	Article number	IE class	Rated		Rated current A	Rated power factor	Efficiency at			Starting current	Starting torque	Break-down torque	Moment of inertia kgm ²	Net weight (IM B3) kg
				speed rpm	torque Nm			100% load %	75% load %	50% load %					
220 VΔ / 380 VY															
0.55	80 M	1LE0021-ODC32-1...	IE2	895	5.9	1.61	0.71	73.1	74.1	70.6	3.8	2.1	2.4	0.0028	18.5
0.75	90 S	1LE0021-OEC02-1...	IE2	935	7.7	2.10	0.71	75.9	76.5	72.7	3.9	2	2.5	0.0038	26
1.1	90 L	1LE0021-OEC42-1...	IE2	945	11.1	3.00	0.71	78.1	78.1	75.7	4.4	2.2	2.7	0.0046	27
1.5	100 L	1LE0021-1AC42-1...	IE2	945	15.2	3.85	0.74	79.8	80.1	78.2	4.6	2.1	2.6	0.0086	34
2.2	112 M	1LE0021-1BC22-1...	IE2	950	22.1	5.6	0.73	81.8	82.5	81	5.2	2.4	3	0.012	44
3	132 S	1LE0021-1CC02-1...	IE2	960	29.8	7.5	0.73	83.3	84.3	83.4	5.2	2	2.8	0.019	56
380 VΔ / 660 VY															
4	132 M	1LE0021-1CC23-3...	IE2	960	39.8	9.8	0.73	84.6	85.4	84.5	5.6	2.1	2.9	0.024	66
5.5	132 M	1LE0021-1CC33-3...	IE2	960	54.7	13.0	0.75	86	86.6	85.7	6	2.3	3.2	0.031	75
7.5	160 M	1LE0021-1DC23-3...	IE2	975	73.5	17.0	0.77	87.2	87.9	87.2	5.8	2	2.9	0.1069	104
11	160 L	1LE0021-1DC43-3...	IE2	975	108	24.0	0.78	88.7	89.4	89.5	6.6	2.2	3.1	0.14	124
15	180 L	1LE0021-1EC43-3...	IE2	975	147	32.5	0.78	89.7	90.4	89.9	6.5	2.3	3	0.18	170
18.5	200 L	1LE0021-2AC43-3...	IE2	975	181	38.5	0.81	90.4	91	91.8	5.8	2.2	2.8	0.27	220
22	200 L	1LE0021-2AC53-3...	IE2	975	215	45.0	0.82	90.9	91.4	91.9	6.5	2.3	2.8	0.32	240
30	225 M	1LE0021-2BC23-3...	IE2	980	292	60	0.83	91.7	92.3	92.7	6.7	2.4	2.8	0.62	294
37	250 M	1LE0021-2CC23-3...	IE2	982	360	73	0.83	92.2	92.8	92.3	7.5	3	2.8	0.91	394
45	280 S	1LE0021-2DC03-3...	IE2	985	436	87	0.85	92.7	93.3	93.5	7.1	2.5	2.8	1.2	510
55	280 M	1LE0021-2DC23-3...	IE2	986	533	106	0.85	93.1	93.7	93.6	7.5	2.4	2.7	1.5	535
75	315 S	1LE0021-3AC03-3...	IE2	986	726	143	0.85	93.7	94.3	93.8	7.5	2.4	3	2.3	680
90	315 M	1LE0021-3AC23-3...	IE2	986	872	171	0.85	94	94.5	94.4	7	2.3	2.8	2.8	835
110	315 L	1LE0021-3AC53-3...	IE2	988	1063	205	0.86	94.3	94.7	94.6	6.5	2.2	2.7	3.9	975
132	315 L	1LE0021-3AC63-3...	IE2	988	1276	245	0.86	94.6	95	94.9	7.8	2.2	2.4	4.3	1030
160	355 M	1LE0021-3BC23-3...	IE2	991	1543	295	0.87	94.8	95.1	93.5	6.5	2	2.1	7.7	1630
185	355 M	1LE0021-3BC33-3...	IE2	991	1785	340	0.87	95	95.3	93.5	6.5	2	2.1	8.4	1690
200	355 M	1LE0021-3BC43-3...	IE2	991	1929	370	0.87	95	95.3	93.6	6.5	2	2.1	9.1	1760
220	355 L	1LE0021-3BC53-3...	IE2	991	2122	405	0.87	95	95.3	93.5	6.5	2	2.1	10.1	1850
250	355 L	1LE0021-3BC63-3...	IE2	991	2412	460	0.87	95	95.3	93.5	6.5	2	2.1	11.4	1950

SIMOTICS Option Line – IE3

Cast-iron series			
Efficiency class	IE3		
Series	1LE0023		
No. of poles	2	4	6
Cooling	Self-ventilated (IC 411)		
Degree of protection	IP55		
Insulation	Thermal class 155 (F)		
Utilization	Thermal class 130 (B)		
Frame size	80 ... 355		
Rated output at 50 Hz	0.55 ... 315 kW		
Rated torque at 50 Hz	2.5 ... 2406.8 Nm		



TIP

The nominal torque of the motor is easy to calculate;
 Torque (Nm) =
 Power (kW) × 9550 / Speed (rpm).

Electrical data – 1LE0 – IE3 – 2-pole (IE3 cast iron) 3000 rpm 2-pole, 400 V 50 Hz																
Rated output 50 Hz kW	Frame size	Motor type	Article number	IE class	Rated speed rpm	Rated torque Nm	Rated current A	Power factor	Efficiency at			Starting current	Starting torque	Break-down torque	Moment of inertia kgm ²	Net weight (IM B3) kg
									100% load %	75% load %	50% load %					
230 VΔ / 400 VY																
0.75	80 M	OCV3082A	1LE0023-ODA22-2...	IE3	2835	2.5	1.56	0.86	80.7	82.9	82.9	6	2.6	3	0.00103	16.0
1.1	80 M	OCV3083A	1LE0023-ODA32-2...	IE3	2850	3.7	2.3	0.83	82.7	84.0	83.9	6.5	2.6	3.4	0.00129	17.5
1.5	90 S	OCV3090A	1LE0023-OEA02-2...	IE3	2870	5.0	3	0.86	84.2	84.8	82.3	7	2	3	0.00229	23
2.2	90 L	OCV3094A	1LE0023-OEA42-2...	IE3	2890	7.3	4.2	0.88	85.9	87.2	86.5	7.5	2.8	3.6	0.00305	27
3	100 L	OCV3104A	1LE0023-1AA42-2...	IE3	2865	10.0	5.7	0.87	87.1	88.3	88.3	8	3.7	3.6	0.00446	37
400 VΔ / 690 VY																
4	112 M	OCV3112A	1LE0023-1BA23-4...	IE3	2915	13.1	7.3	0.90	88.1	89.6	89.8	7.8	2.6	3.6	0.0085	45
5.5	132 S	OCV3130A	1LE0023-1CA03-4...	IE3	2930	17.9	10	0.89	89.2	90.2	90.3	7.5	2.3	3.6	0.0175	59
7.5	132 S	OCV3131A	1LE0023-1CA13-4...	IE3	2930	24.4	13.4	0.90	90.1	91.5	92.2	7.5	2.3	3.6	0.0220	67
11	160 M	OCV3162A	1LE0023-1DA23-4...	IE3	2935	35.8	19.6	0.89	91.2	92.0	91.7	7.5	2.3	3.4	0.0369	97
15	160 M	OCV3163A	1LE0023-1DA33-4...	IE3	2935	48.8	26.5	0.89	91.9	92.6	92.5	7.5	2.4	3.4	0.0451	108
18.5	160 L	OCV3164A	1LE0023-1DA43-4...	IE3	2935	60.2	32.5	0.89	92.4	93.0	92.9	7.8	2.4	3.4	0.0542	123
22	180 M	OCV3182A	1LE0023-1EA23-4...	IE3	2950	71.2	38.5	0.89	92.7	93.0	92.4	7.8	2.4	3.4	0.0835	162
30	200 L	OCV3204A	1LE0023-2AA43-4...	IE3	2955	97.0	52	0.89	93.3	93.4	92.4	7.8	2.4	3.4	0.146	219
37	200 L	OCV3205A	1LE0023-2AA53-4...	IE3	2960	119	64	0.89	93.7	93.9	93.3	8.5	2.8	3.4	0.181	248
45	225 M	OCV3222A	1LE0023-2BA23-4...	IE3	2965	145	78	0.89	94.0	94.3	93.8	7.8	2.4	3.2	0.301	322
55	250M	OCV3252A	1LE0023-2CA23-4...	IE3	2975	177	95	0.89	94.3	94.1	93.1	7.8	2.4	3.2	0.509	373
75	280S	OCV3280A	1LE0023-2DA03-4...	IE3	2975	241	128	0.89	94.7	94.8	94.1	7.2	2.4	3.4	0.87	515
90	280M	OCV3282A	1LE0023-2DA23-4...	IE3	2975	289	152	0.90	95.0	95.3	95.0	7.5	2.8	3.4	1.04	585
110	315S	OCV3310A	1LE0023-3AA03-4...	IE3	2985	352	185	0.90	95.2	95.1	94.5	7.9	2.3	2.6	1.57	795
132	315M	OCV3312A	1LE0023-3AA23-4...	IE3	2982	423	220	0.90	95.4	95.3	92.4	7.9	2.3	2.6	1.66	830
160	315L	OCV3315A	1LE0023-3AA53-4...	IE3	2978	513	265	0.91	95.6	95.7	95.3	7.9	2.1	2.6	1.98	955
185	315L	OCV3316A	1LE0023-3AA63-4...	IE3	2985	592	305	0.92	95.7	95.9	95.7	9	2.6	2.6	2.38	1070
200	315L	OCV3317A	1LE0023-3AA73-4...	IE3	2982	641	330	0.92	95.8	95.9	95.7	8.5	2.6	3.2	2.38	1080
220	355M	OCV3352A	1LE0023-3BA23-4...	IE3	2986	704	370	0.90	95.8	95.4	94.2	8.5	2.2	2.8	2.63	1360
250	355M	OCV3353A	1LE0023-3BA33-4...	IE3	2985	800	420	0.90	95.8	95.7	94.6	8	2.2	2.8	2.63	1370
280	355L	OCV3355A	1LE0023-3BA53-4...	IE3	2988	895	470	0.90	95.8	95.7	94.9	8.5	2.2	2.8	3.23	1600
315	355L	OCV3356A	1LE0023-3BA63-4...	IE3	2982	1009	530	0.90	95.8	95.8	95.3	8	2.2	2.8	3.23	1620

SIMOTICS Option Line – IE3

Cast-iron series			
Efficiency class	IE3		
Series	1LE0023		
No. of poles	2	4	6
Cooling	Self-ventilated (IC 411)		
Degree of protection	IP55		
Insulation	Thermal class 155 (F)		
Utilization	Thermal class 130 (B)		
Frame size	80 ... 355		
Rated output at 50 Hz	0.55 ... 315 kW		
Rated torque at 50 Hz	2.5 ... 2406.8 Nm		



TIP
 The nominal torque of the motor is easy to calculate;
 Torque (Nm) =
 Power (kW) × 9550 / Speed (rpm).

Electrical data – 1LE0 – IE3 – 4-pole (IE3 cast iron) 1500 rpm 4-pole, 400 V 50 Hz																
Rated output 50 Hz kW	Frame size	Motor type	Article number	IE class	Rated		Rated current A	Power factor	Efficiency at			Starting current rpm	Starting torque	Break-down torque	Moment of inertia kgm ²	Net Weight (IM B3) kg
					speed rpm	torque Nm			100% load %	75% load %	50% load %					
230 VΔ / 400 VY																
0.55	80 M	OCV3082B	1LE0023-0DB22-2	IE3	1445	3.6	1.29	0.76	80.8	81.8	80.2	5.5	2.2	3.2	0.00207	17.0
0.75	80 M	OCV3083B	1LE0023-0DB32-2	IE3	1440	5.0	1.75	0.75	82.5	82.9	80.7	6	2.6	3.7	0.00242	18.0
1.1	90 S	OCV3090B	1LE0023-0EB02-2	IE3	1445	7.3	2.4	0.79	84.1	85.1	83.9	6.5	2.7	3.7	0.00377	23
1.5	90 L	OCV3094B	1LE0023-0EB42-2	IE3	1445	9.9	3.2	0.79	85.3	86.0	85.2	6.5	2.8	3.8	0.00484	27
2.2	100 L	OCV3104B	1LE0023-1AB42-2	IE3	1445	14.5	4.45	0.82	86.7	87.1	85.7	8.3	3.4	4.6	0.01030	40
3	100 L	OCV3105B	1LE0023-1AB52-2	IE3	1440	19.9	6	0.82	87.7	88.1	87.1	8.3	3.7	4.6	0.01273	44
400 VΔ / 690 VY																
4	112 M	OCV3112B	1LE0023-1BB23-4	IE3	1450	26.3	7.9	0.82	88.6	89.6	89.2	7.8	3.7	4.6	0.0144	49
5.5	132 S	OCV3130B	1LE0023-1CB03-4	IE3	1455	36.1	10.5	0.84	89.6	90.9	91.1	7.8	2.6	3.8	0.0276	66
7.5	132 M	OCV3132B	1LE0023-1CB23-4	IE3	1455	49.2	14.1	0.85	90.4	91.7	93.2	7.8	2.6	3.8	0.0345	78
11	160 M	OCV3162B	1LE0023-1DB23-4	IE3	1465	71.7	20	0.86	91.4	92.4	92.6	7.8	2.4	3.8	0.0626	105
15	160 L	OCV3164B	1LE0023-1DB43-4	IE3	1465	97.8	27.5	0.86	92.1	92.9	93.0	8.2	2.6	3.8	0.0782	122
18.5	180 M	OCV3182B	1LE0023-1EB23-4	IE3	1470	120	34.5	0.83	92.6	93.0	92.5	7.8	2.6	3.6	0.1339	162
22	180 L	OCV3184B	1LE0023-1EB43-4	IE3	1470	143	41	0.83	93.0	93.7	93.6	7.8	2.6	3.6	0.1531	178
30	200 L	OCV3204B	1LE0023-2AB43-4	IE3	1475	194	55	0.84	93.6	94.3	94.2	7.8	2.6	3.6	0.245	234
37	225 S	OCV3220B	1LE0023-2BB03-4	IE3	1482	238	67	0.85	93.9	94.1	93.4	8.3	3	3.6	0.515	294
45	225 M	OCV3222B	1LE0023-2BB23-4	IE3	1482	290	81	0.85	94.2	94.2	93.7	8.3	3.3	3.6	0.548	322
55	250M	OCV3252B	1LE0023-2CB23-4...	IE3	1485	354	98	0.86	94.6	95.0	94.7	7.6	2.6	3.3	0.896	409
75	280S	OCV3280B	1LE0023-2DB03-4...	IE3	1485	482	133	0.86	95.0	95.3	95.3	7.6	2.6	3	1.47	550
90	280M	OCV3282B	1LE0023-2DB23-4	IE3	1485	579	157	0.87	95.2	95.6	95.5	7.6	2.6	3	1.87	640
110	315S	OCV3310B	1LE0023-3AB03-4...	IE3	1488	706	191	0.87	95.4	95.7	95.4	7.9	3	3	2.39	745
132	315M	OCV3312B	1LE0023-3AB23-4...	IE3	1488	847	230	0.87	95.6	95.9	95.5	7.9	3	3	3.01	900
160	315L	OCV3315B	1LE0023-3AB53-4...	IE3	1488	1027	275	0.87	95.8	96.1	95.8	7.9	3	3	3.33	985
185	315L	OCV3316B	1LE0023-3AB63-4...	IE3	1488	1187	320	0.87	95.9	96.2	95.8	8.5	3	3	3.77	1060
200	315L	OCV3317B	1LE0023-3AB73-4...	IE3	1488	1284	340	0.88	96.0	96.3	96.1	8.5	3	2.6	4.13	1110
220	355M	OCV3352B	1LE0023-3BB23-4...	IE3	1490	1410	375	0.88	96.0	96.0	95.3	8	2	3.2	4.97	1530
250	355M	OCV3353B	1LE0023-3BB33-4...	IE3	1490	1602	425	0.88	96.0	96.0	95.3	7.8	1.8	2.9	4.97	1550
280	355L	OCV3355B	1LE0023-3BB53-4...	IE3	1490	1795	480	0.88	96.0	96.1	95.7	7.8	1.8	2.9	6.52	1680
315	355L	OCV3356B	1LE0023-3BB63-4...	IE3	1490	2019	540	0.88	96.0	96.1	95.8	8	1.8	2.9	7.06	1770

SIMOTICS Option Line – IE3

Cast-iron series			
Efficiency class	IE3		
Series	1LE0023		
No. of poles	2	4	6
Cooling	Self-ventilated (IC 411)		
Degree of protection	IP55		
Insulation	Thermal class 155 (F)		
Utilization	Thermal class 130 (B)		
Frame size	80 ... 355		
Rated output at 50 Hz	0.55 ... 315 kW		
Rated torque at 50 Hz	2.5 ... 2406.8 Nm		



The nominal torque of the motor is easy to calculate;
 Torque (Nm) =
 Power (kW) × 9550 / Speed (rpm).

Electrical data – 1LE0 – IE3 – 6-pole (IE3 cast iron) 1000 rpm 6-pole, 400 V 50 Hz																
Rated output 50 Hz kW	Frame size	Motor type	Article number	IE class	Rated		Power factor	Efficiency at			Starting current	Break-down torque	Moment of inertia	Weight (IM B3)		
					speed rpm	torque Nm		Rated current A	100% load %	75% load %					50% load %	
230 VΔ / 400 VY																
0.55	80 M	OCV3083C	1LE0023-ODC32-2	IE3	940	5.6	1.53	0.67	77.2	77.5	74.6	5	2.7	3.4	0.00298	19.0
0.75	90 S	OCV3090C	1LE0023-OEC02-2	IE3	940	7.6	1.96	0.70	78.9	80.3	78.0	5	2.4	3.2	0.00422	24
1.1	90 L	OCV3094C	1LE0023-OEC42-2	IE3	945	11.1	2.85	0.69	81.0	81.6	80.4	5.5	2.7	3.5	0.00497	27
1.5	100 L	OCV3104C	1LE0023-1AC42-2	IE3	950	15.1	3.55	0.74	82.5	84.1	82.9	5.5	2.5	3.5	0.01107	41
2.2	112 M	OCV3112C	1LE0023-1BC22-2	IE3	945	22.2	5.1	0.74	84.3	86.1	95.7	6	2.7	3.4	0.01414	48
3	132 S	OCV3130C	1LE0023-1CC02-2	IE3	965	29.7	6.7	0.75	85.6	86.6	86.0	6	2.7	4	0.02333	59
400 VΔ / 690 VY																
4	132 M	OCV3132C	1LE0023-1CC23-4	IE3	960	39.8	8.9	0.75	86.8	88.5	88.7	6	2.7	3.4	0.0297	70
5.5	132 M	OCV3133C	1LE0023-1CC33-4	IE3	960	54.7	11.9	0.76	88.0	89.2	89.0	6.5	2.7	4	0.0402	84
7.5	160 M	OCV3162C	1LE0023-1DC23-4	IE3	980	73.1	15.6	0.78	89.1	90.4	90.3	6.5	2.7	3.6	0.1197	105
11	160 L	OCV3164C	1LE0023-1DC43-4	IE3	980	107	23	0.77	90.3	90.3	89.8	7	2.7	3.6	0.1605	129
15	180 L	OCV3184C	1LE0023-1EC43-4	IE3	975	147	29.5	0.80	91.2	92.1	91.8	7	2.3	3	0.2008	163
18.5	200 L	OCV3204C	1LE0023-2AC43-4	IE3	978	181	36.5	0.80	91.7	92.5	92.2	7	2.3	3	0.312	212
22	200 L	OCV3205C	1LE0023-2AC53-4	IE3	980	214	43	0.80	92.2	93.1	93.0	7	2.6	3	0.356	229
30	225 M	OCV3222C	1LE0023-2BC23-4	IE3	982	292	56	0.83	92.9	93.9	94.3	7.6	2.6	3	0.740	321
37	250M	OCV3252C	1LE0023-2CC23-4...	IE3	985	359	68	0.84	93.3	94.1	94.1	7.8	2.6	3	1.26	395
45	280S	OCV3280C	1LE0023-2DC03-4...	IE3	988	435	83	0.84	93.7	94.5	94.4	7.8	3	3	1.45	494
55	280M	OCV3282C	1LE0023-2DC23-4...	IE3	988	532	100	0.84	94.1	94.6	94.5	7.8	3	3	1.77	555
75	315S	OCV3310C	1LE0023-3AC03-4...	IE3	990	723	136	0.84	94.6	95.0	94.7	7.8	2.4	3	2.75	725
90	315M	OCV3312C	1LE0023-3AC23-4...	IE3	990	868	163	0.84	94.9	95.3	94.9	7.8	2.6	3	3.34	835
110	315L	OCV3315C	1LE0023-3AC53-4...	IE3	991	1060	196	0.85	95.1	95.3	94.9	8.2	2.4	2.4	4.32	1010
132	315L	OCV3316C	1LE0023-3AC63-4...	IE3	991	1272	235	0.85	95.4	95.7	95.4	8.2	2.6	3	4.62	1050
160	355M	OCV3352C	1LE0023-3BC23-4...	IE3	994	1537	290	0.84	95.6	95.7	95.2	8.5	3	2.4	10.40	1640
185	355M	OCV3353C	1LE0023-3BC33-4....	IE3	993	1779	330	0.84	95.7	95.8	95.3	8.5	3	2	10.40	1650
200	355M	OCV3354C	1LE0023-3BC43-4....	IE3	993	1923	360	0.84	95.8	95.9	95.4	8.5	3	2.4	10.87	1700
220	355L	OCV3355C	1LE0023-3BC53-4...	IE3	993	2116	395	0.84	95.8	96.0	95.6	8.5	3	2.4	12.86	1940
250	355L	OCV3356C	1LE0023-3BC63-4...	IE3	992	2407	450	0.84	95.8	96.1	95.9	8.5	3	2.4	12.86	1970

SIMOTICS Option Line – IE3

Cast-iron series	
Efficiency class	IE3
Series	1LE0023
No. of poles	2 4 6
Cooling	Self-ventilated (IC 411)
Degree of protection	IP55
Insulation	Thermal class 155 (F)
Utilization	Thermal class 130 (B)
Frame size	80 ... 355
Rated output at 50 Hz	0.55 ... 315 kW
Rated torque at 50 Hz	2.5 ... 2406.8 Nm



TIP

The nominal torque of the motor is easy to calculate;
 Torque (Nm) =
 Power (kW) × 9550 / Speed (rpm).

Electrical data – 1LE0 – IE3 – 2-pole														(IE3 cast iron) 3000 rpm 2-pole, 380 VΔ 50 Hz			
Rated output kW	Frame size	Motor type	Article number	IE class	Rated torque		Rated current A	Power factor	Efficiency at			Starting current	Starting torque	Break-down torque	Moment of inertia kgm ²	Weight (IM B3) kg	
					speed rpm	Nm			100% load %	75% load %	50% load %						
220 VΔ / 380 VY																	
0.75	80 M	OCV3082A	1LE0023-ODA22-1...	IE3	2835	2.5	1.64	0.86	80.7	82.9	82.9	6	2.6	3	0.00103	16.0	
1.1	80 M	OCV3083A	1LE0023-ODA32-1...	IE3	2850	3.7	2.45	0.83	82.7	84.0	83.9	6.5	2.6	3.4	0.00129	17.5	
1.5	90 S	OCV3090A	1LE0023-OEA02-1...	IE3	2870	5.0	3.15	0.86	84.2	84.8	82.3	7	2	3	0.00229	23	
2.2	90 L	OCV3094A	1LE0023-OEA42-1...	IE3	2890	7.3	4.4	0.88	85.9	87.2	86.5	7.5	2.8	3.6	0.00305	27	
3	100 L	OCV3104A	1LE0023-1AA42-1...	IE3	2865	10.0	6	0.87	87.1	88.3	88.3	8	3.7	3.6	0.00446	37	
380 VΔ / 660 VY																	
4	112 M	OCV3112A	1LE0023-1BA23-3...	IE3	2915	13.1	7.7	0.90	88.1	89.6	89.8	7.8	2.6	3.6	0.0085	45	
5.5	132 S	OCV3130A	1LE0023-1CA03-3...	IE3	2930	17.9	10.5	0.89	89.2	90.2	90.3	7.5	2.3	3.6	0.0175	59	
7.5	132 S	OCV3131A	1LE0023-1CA13-3...	IE3	2930	24.4	14.1	0.90	90.1	91.5	92.2	7.5	2.3	3.6	0.0220	67	
11	160 M	OCV3162A	1LE0023-1DA23-3...	IE3	2935	35.8	20.5	0.89	91.2	92.0	91.7	7.5	2.3	3.4	0.0369	97	
15	160 M	OCV3163A	1LE0023-1DA33-3...	IE3	2935	48.8	28	0.89	91.9	92.6	92.5	7.5	2.4	3.4	0.0451	108	
18.5	160 L	OCV3164A	1LE0023-1DA43-3...	IE3	2935	60.2	34	0.89	92.4	93.0	92.9	7.8	2.4	3.4	0.0542	123	
22	180 M	OCV3182A	1LE0023-1EA23-3...	IE3	2950	71.2	40.5	0.89	92.7	93.0	92.4	7.8	2.4	3.4	0.0835	162	
30	200 L	OCV3204A	1LE0023-2AA43-3...	IE3	2955	97.0	55	0.89	93.3	93.4	92.4	7.8	2.4	3.4	0.146	219	
37	200 L	OCV3205A	1LE0023-2AA53-3...	IE3	2960	119	67	0.89	93.7	93.9	93.3	8.5	2.8	3.4	0.181	248	
45	225 M	OCV3222A	1LE0023-2BA23-3...	IE3	2965	145	82	0.89	94.0	94.3	93.8	7.8	2.4	3.2	0.301	322	
55	250M	OCV3252A	1LE0023-2CA23-3...	IE3	2975	177	100	0.89	94.3	94.1	93.1	7.8	2.4	3.2	0.509	373	
75	280S	OCV3280A	1LE0023-2DA03-3...	IE3	2975	241	135	0.89	94.7	94.8	94.1	7.2	2.4	3.4	0.87	515	
90	280M	OCV3282A	1LE0023-2DA23-3...	IE3	2975	289	160	0.90	95.0	95.3	95.0	7.5	2.8	3.4	1.04	585	
110	315S	OCV3310A	1LE0023-3AA03-3...	IE3	2985	352	195	0.90	95.2	95.1	94.5	7.9	2.3	2.6	1.57	795	
132	315M	OCV3312A	1LE0023-3AA23-3...	IE3	2982	423	235	0.90	95.4	95.3	92.4	7.9	2.3	2.6	1.66	830	
160	315L	OCV3315A	1LE0023-3AA53-3...	IE3	2978	513	280	0.91	95.6	95.7	95.3	7.9	2.1	2.6	1.98	955	
185	315L	OCV3316A	1LE0023-3AA63-3...	IE3	2985	592	320	0.92	95.7	95.9	95.7	9	2.6	2.6	2.38	1070	
200	315L	OCV3317A	1LE0023-3AA73-3...	IE3	2982	641	345	0.92	95.8	95.9	95.7	8.5	2.6	3.2	2.38	1080	
220	355M	OCV3352A	1LE0023-3BA23-3...	IE3	2986	704	390	0.90	95.8	95.4	94.2	8.5	2.2	2.8	2.63	1360	
250	355M	OCV3353A	1LE0023-3BA33-3...	IE3	2985	800	440	0.90	95.8	95.7	94.6	8	2.2	2.8	2.63	1370	
280	355L	OCV3355A	1LE0023-3BA53-3...	IE3	2988	895	495	0.90	95.8	95.7	94.9	8.5	2.2	2.8	3.23	1600	
315	355L	OCV3356A	1LE0023-3BA63-3...	IE3	2982	1009	560	0.90	95.8	95.8	95.3	8	2.2	2.8	3.23	1620	

SIMOTICS Option Line – IE3

Cast-iron series			
Efficiency class	IE3		
Series	1LE0023		
No. of poles	2	4	6
Cooling	Self-ventilated (IC 411)		
Degree of protection	IP55		
Insulation	Thermal class 155 (F)		
Utilization	Thermal class 130 (B)		
Frame size	80 ... 355		
Rated output at 50 Hz	0.55 ... 315 kW		
Rated torque at 50 Hz	2.5 ... 2406.8 Nm		



TIP
 The nominal torque of the motor is easy to calculate;
 Torque (Nm) =
 Power (kW) × 9550 / Speed (rpm).

Electrical data – 1LE0 – IE3 – 4-pole (IE3 cast iron) 1500 rpm 4-pole, 380 VΔ 50 Hz																
Rated output kW	Frame size	Motor type	Article number	IE class	Rated speed rpm	Rated torque Nm	Rated current A	Power factor	Efficiency at			Starting current	Starting torque	Break-down torque	Moment of inertia kgm ²	Net weight (IM B3) kg
									100% load %	75% load %	50% load %					
220 VΔ / 380 VY																
0.55	80 M	OCV3082B	1LE0023-0DB22-1	IE3	1445	3.6	1.36	0.76	80.8	81.8	80.2	5.5	2.2	3.2	0.00207	17.0
0.75	80 M	OCV3083B	1LE0023-0DB32-1	IE3	1440	5.0	1.84	0.75	82.5	82.9	80.7	6	2.6	3.7	0.00242	18.0
1.1	90 S	OCV3090B	1LE0023-0EB02-1	IE3	1445	7.3	2.5	0.79	84.1	85.1	83.9	6.5	2.7	3.7	0.00377	23
1.5	90 L	OCV3094B	1LE0023-0EB42-1	IE3	1445	9.9	3.4	0.79	85.3	86.0	85.2	6.5	2.8	3.8	0.00484	27
2.2	100 L	OCV3104B	1LE0023-1AB42-1	IE3	1445	14.5	4.7	0.82	86.7	87.1	85.7	8.3	3.4	4.6	0.01030	40
3	100 L	OCV3105B	1LE0023-1AB52-1	IE3	1440	19.9	6.3	0.82	87.7	88.1	87.1	8.3	3.7	4.6	0.01273	44
380 VΔ / 660 VY																
4	112 M	OCV3112B	1LE0023-1BB23-3	IE3	1450	26.3	8.4	0.82	88.6	89.6	89.2	7.8	3.7	4.6	0.0144	49
5.5	132 S	OCV3130B	1LE0023-1CB03-3	IE3	1455	36.1	11.1	0.84	89.6	90.9	91.1	7.8	2.6	3.8	0.0276	66
7.5	132 M	OCV3132B	1LE0023-1CB23-3	IE3	1455	49.2	14.8	0.85	90.4	91.7	93.2	7.8	2.6	3.8	0.0345	78
11	160 M	OCV3162B	1LE0023-1DB23-3	IE3	1465	71.7	21.5	0.86	91.4	92.4	92.6	7.8	2.4	3.8	0.0626	105
15	160 L	OCV3164B	1LE0023-1DB43-3	IE3	1465	97.8	29	0.86	92.1	92.9	93.0	8.2	2.6	3.8	0.0782	122
18.5	180 M	OCV3182B	1LE0023-1EB23-3	IE3	1470	120	36.5	0.83	92.6	93.0	92.5	7.8	2.6	3.6	0.1339	162
22	180 L	OCV3184B	1LE0023-1EB43-3	IE3	1470	143	43.5	0.83	93.0	93.7	93.6	7.8	2.6	3.6	0.1531	178
30	200 L	OCV3204B	1LE0023-2AB43-3	IE3	1475	194	58	0.84	93.6	94.3	94.2	7.8	2.6	3.6	0.245	234
37	225 S	OCV3220B	1LE0023-2BB03-3	IE3	1482	238	70	0.85	93.9	94.1	93.4	8.3	3	3.6	0.515	294
45	225 M	OCV3222B	1LE0023-2BB23-3	IE3	1482	290	85	0.85	94.2	94.2	93.7	8.3	3.3	3.6	0.548	322
55	250M	OCV3252B	1LE0023-2CB23-3...	IE3	1485	354	103	0.86	94.6	95.0	94.7	7.6	2.6	3.3	0.896	409
75	280S	OCV3280B	1LE0023-2DB03-3...	IE3	1485	482	139	0.86	95.0	95.3	95.3	7.6	2.6	3	1.47	550
90	280M	OCV3282B	1LE0023-2DB23-3	IE3	1485	579	165	0.87	95.2	95.6	95.5	7.6	2.6	3	1.87	640
110	315S	OCV3310B	1LE0023-3AB03-3...	IE3	1488	706	200	0.87	95.4	95.7	95.4	7.9	3	3	2.39	745
132	315M	OCV3312B	1LE0023-3AB23-3...	IE3	1488	847	240	0.87	95.6	95.9	95.5	7.9	3	3	3.01	900
160	315L	OCV3315B	1LE0023-3AB53-3...	IE3	1488	1027	290	0.87	95.8	96.1	95.8	7.9	3	3	3.33	985
185	315L	OCV3316B	1LE0023-3AB63-3...	IE3	1488	1187	335	0.87	95.9	96.2	95.8	8.5	3	3	3.77	1060
200	315L	OCV3317B	1LE0023-3AB73-3...	IE3	1488	1284	360	0.88	96.0	96.3	96.1	8.5	3	2.6	4.13	1110
220	355M	OCV3352B	1LE0023-3BB23-3...	IE3	1490	1410	395	0.88	96.0	96.0	95.3	8	2	3.2	4.97	1530
250	355M	OCV3353B	1LE0023-3BB33-3...	IE3	1490	1602	450	0.88	96.0	96.0	95.3	7.8	1.8	2.9	4.97	1550
280	355L	OCV3355B	1LE0023-3BB53-3...	IE3	1490	1795	500	0.88	96.0	96.1	95.7	7.8	1.8	2.9	6.52	1680
315	355L	OCV3356B	1LE0023-3BB63-3...	IE3	1490	2019	570	0.88	96.0	96.1	95.8	8	1.8	2.9	7.06	1770

SIMOTICS Option Line – IE3

Cast-iron series			
Efficiency class	IE3		
Series	1LE0023		
No. of poles	2	4	6
Cooling	Self-ventilated (IC 411)		
Degree of protection	IP55		
Insulation	Thermal class 155 (F)		
Utilization	Thermal class 130 (B)		
Frame size	80 ... 355		
Rated output at 50 Hz	0.55 ... 315 kW		
Rated torque at 50 Hz	2.5 ... 2406.8 Nm		



The nominal torque of the motor is easy to calculate;
 Torque (Nm) =
 Power (kW) × 9550 / Speed (rpm).

Electrical data – 1LE0 – IE3 – 6-pole (IE3 cast iron) 1000 rpm 6-pole, 380 VΔ 50 Hz																
Rated output kW	Frame size	Motor type	Article number	IE class	Rated torque		Rated current A	Power factor	Efficiency at			Starting current	Starting torque	Break-down torque	Moment of inertia kgm ²	Net weight (IM B3) kg
					speed rpm	Nm			100% load %	75% load %	50% load %					
220 VΔ / 380 VY																
0.55	80 M	OCV3083C	1LE0023-0DC32-1	IE3	940	5.6	1.62	0.67	77.2	77.5	74.6	5	2.7	3.4	0.00298	19.0
0.75	90 S	OCV3090C	1LE0023-0EC02-1	IE3	940	7.6	2.05	0.70	78.9	80.3	78.0	5	2.4	3.2	0.00422	24
1.1	90 L	OCV3094C	1LE0023-0EC42-1	IE3	945	11.1	3	0.69	81.0	81.6	80.4	5.5	2.7	3.5	0.00497	27
1.5	100 L	OCV3104C	1LE0023-1AC42-1	IE3	950	15.1	3.75	0.74	82.5	84.1	82.9	5.5	2.5	3.5	0.01107	41
2.2	112 M	OCV3112C	1LE0023-1BC22-1	IE3	945	22.2	5.4	0.74	84.3	86.1	95.7	6	2.7	3.4	0.01414	48
3	132 S	OCV3130C	1LE0023-1CC02-1	IE3	965	29.7	7.1	0.75	85.6	86.6	86.0	6	2.7	4	0.02333	59
380 VΔ / 660 VY																
4	132 M	OCV3132C	1LE0023-1CC23-3	IE3	960	39.8	9.3	0.75	86.8	88.5	88.7	6	2.7	3.4	0.0297	70
5.5	132 M	OCV3133C	1LE0023-1CC33-3	IE3	960	54.7	12.5	0.76	88.0	89.2	89.0	6.5	2.7	4	0.0402	84
7.5	160 M	OCV3162C	1LE0023-1DC23-3	IE3	980	73.1	16.4	0.78	89.1	90.4	90.3	6.5	2.7	3.6	0.1197	105
11	160 L	OCV3164C	1LE0023-1DC43-3	IE3	980	107	24	0.77	90.3	90.3	89.8	7	2.7	3.6	0.1605	129
15	180 L	OCV3184C	1LE0023-1EC43-3	IE3	975	147	31	0.80	91.2	92.1	91.8	7	2.3	3	0.2008	163
18.5	200 L	OCV3204C	1LE0023-2AC43-3	IE3	978	181	38.5	0.80	91.7	92.5	92.2	7	2.3	3	0.312	212
22	200 L	OCV3205C	1LE0023-2AC53-3	IE3	980	214	45.5	0.80	92.2	93.1	93.0	7	2.6	3	0.356	229
30	225 M	OCV3222C	1LE0023-2BC23-3	IE3	982	292	59	0.83	92.9	93.9	94.3	7.6	2.6	3	0.740	321
37	250M	OCV3252C	1LE0023-2CC23-3...	IE3	985	359	72	0.84	93.3	94.1	94.1	7.8	2.6	3	1.26	395
45	280S	OCV3280C	1LE0023-2DC03-3...	IE3	988	435	87	0.84	93.7	94.5	94.4	7.8	3	3	1.45	494
55	280M	OCV3282C	1LE0023-2DC23-3...	IE3	988	532	106	0.84	94.1	94.6	94.5	7.8	3	3	1.77	555
75	315S	OCV3310C	1LE0023-3AC03-3...	IE3	990	723	143	0.84	94.6	95.0	94.7	7.8	2.4	3	2.75	725
90	315M	OCV3312C	1LE0023-3AC23-3...	IE3	990	868	172	0.84	94.9	95.3	94.9	7.8	2.6	3	3.34	835
110	315L	OCV3315C	1LE0023-3AC53-3...	IE3	991	1060	205	0.85	95.1	95.3	94.9	8.2	2.4	2.4	4.32	1010
132	315L	OCV3316C	1LE0023-3AC63-3...	IE3	991	1272	245	0.85	95.4	95.7	95.4	8.2	2.6	3	4.62	1050
160	355M	OCV3352C	1LE0023-3BC23-3...	IE3	994	1537	305	0.84	95.6	95.7	95.2	8.5	3	2.4	10.40	1640
185	355M	OCV3353C	1LE0023-3BC33-3....	IE3	993	1779	350	0.84	95.7	95.8	95.3	8.5	3	2	10.40	1650
200	355M	OCV3354C	1LE0023-3BC43-3....	IE3	993	1923	380	0.84	95.8	95.9	95.4	8.5	3	2.4	10.87	1700
220	355L	OCV3355C	1LE0023-3BC53-3...	IE3	993	2116	415	0.84	95.8	96.0	95.6	8.5	3	2.4	12.86	1940
250	355L	OCV3356C	1LE0023-3BC63-3...	IE3	992	2407	470	0.84	95.8	96.1	95.9	8.5	3	2.4	12.86	1970

SIMOTICS Option Line – List of options

Remark: The basic 1LE0 extended option motor does not include any option as standard.

Motor frame size	12 th & 13 th position of the Article No.	Option code	Description
Voltage and frequency			
FS 80 ~ 280	21		220 VΔ/380 VY 50 Hz, 440 VY 60 Hz ²⁾
FS 80 ~ 355	33		380 VΔ/660 VY 50 Hz, 440 VΔ 60 Hz ²⁾
FS 80 ~ 280	22		230 VΔ/400 VY 50 Hz, 460 VY 60 Hz ²⁾
FS 80 ~ 355	34		400 VΔ/690 VY 50 Hz, 460 VΔ 60 Hz ²⁾
FS 80 ~ 355	23		240 VΔ/415 VY 50 Hz
FS 80 ~ 355	35		415 VΔ 50 Hz
FS 80 ~ 355	41		525 VΔ 50 Hz
FS 80 ~ 355	90	M2A ¹⁾	220 VΔ/380 VY 60 Hz (50 Hz output)
FS 80 ~ 355	90	M2B ¹⁾	380 VΔ/660 VY 60 Hz (50 Hz output)
FS 80 ~ 280	90	M2C ¹⁾	440 VY 60 Hz (50 Hz output)
FS 80 ~ 355	90	M2D ¹⁾	440 VΔ 60 Hz (50 Hz output)
FS 80 ~ 280	90	M2E ¹⁾	460 VY 60 Hz (50 Hz output)
FS 80 ~ 355	90	M2F ¹⁾	460 VΔ 60 Hz (50 Hz output)
FS 80 ~ 280	90	M1A ¹⁾	220 VΔ/380 VY 60 Hz (60 Hz output)
FS 80 ~ 355	90	M1B ¹⁾	380 VΔ/660 VY 60 Hz (60 Hz output)
FS 80 ~ 280	90	M1C ¹⁾	440 VY 60 Hz (60 Hz output)
FS 80 ~ 355	90	M1D ¹⁾	440 VΔ 60 Hz (60 Hz output)
FS 80 ~ 280	90	M1E ¹⁾	460 VY 60 Hz (60 Hz output)
FS 80 ~ 355	90	M1F ¹⁾	460 VΔ 60 Hz (60 Hz output)
FS 80 ~ 280	90	M1K ¹⁾	480VY 60Hz (60 Hz output)
FS 80 ~ 355	90	M1L ¹⁾	480VΔ 60Hz(60Hz output)
Motor frame size	15 th position of the Article No.	Option code	Description
Motor protection			
FS 80 ~ 355	A ²⁾		Without motor protection
FS 80 ~ 355	B		Motor protection with PTC thermistors with three embedded temperature sensors for tripping
FS 80 ~ 355	C		Motor protection with PTC thermistors with 6 embedded temperature sensors for alarm and tripping
FS 100 ~ 355	K		Installation of 1 single 2 wires PT1000 resistance thermometers
FS 80 ~ 355	H		Installation of three Pt100 resistance thermometers
FS 80 ~ 355	J		Installation of six Pt100 resistance thermometers
Motor frame size	16 th position of the Article No.	Option code	Description
Motor terminal box			
FS 80 ~ 355	4		Terminal box top, cable entry on right (view from DE)
FS 80 ~ 355	5		Terminal box on RHS
FS 80 ~ 355	6		Terminal box on LHS
FS 80 ~ 355		R10 ³⁾	Rotation of the terminal box through 90°, entry from DE
FS 80 ~ 355		R11	Rotation of the terminal box through 90°, entry from NDE
FS 80 ~ 355		R12	Rotation of the terminal box through 180°, cable entry at left side from DE view
FS 80 ~ 355		H08	Terminal box on NDE
FS 200 ~ 355		L97	Additional connection box
Windings and insulation			
FS 80 ~ 355		N01 ⁴⁾	Temperature class 155 (F), used acc. to 155 (F), with service factor (SF) 1.15
FS 80 ~ 355		N10	Temperature class 180 (H)
FS 80 ~ 355		Q04	Anti-condensation heating for 220 V
FS 80 ~ 355		Q02	Anti-condensation heating for 230 V

¹⁾ If 60Hz option is selected for 1LE0023 motors, there will be no CE mark on nameplate.

²⁾ Without additional charge. No 60 Hz data on nameplate for 1LE0023.

³⁾ For FS 80 to 112 motor, R10 only in combination with option code H08 (Terminal box on NDE) possible.

⁴⁾ N01 not possible for inverter operation.

TIP



For FS 80 ... 160, the floating bearings are assembled. For FS 180 ... 355, the floating bearing at DE, and the fixed bearing at NDE are assembled. If vertical mounting, the axial and trust load have to be considered.

Motor frame size	Option code ¹⁾	Description
Bearings		
FS 100 ~ 355	L22 ⁵⁾	Bearing design for increased cantilever forces
FS 80 ~ 160	L20	Located bearing DE
FS 100 ~ 250	L23 ⁶⁾	Regreasing device
FS 180 ~ 355	Q72	Installation of 2 Pt100 screw-in resistance thermometers for bearings
FS 250 ~ 355	L53 ⁷⁾	Insulated bearing non-drive end
FS 100 ~ 355	Q01	Measuring nipple for SPM shock pulse measurement for bearing inspection
FS 80 - 355	L80	SKF bearing
Balance and vibration quantity		
FS 80 ~ 355	L00	Vibration quantity level B
Mechanical version and degree of protection		
FS 80 ~ 355	L05 ⁸⁾⁹⁾	Second standard shaft extension
FS 80 ~ 355	H00 ¹⁰⁾	Protective cover (canopy)
FS 80 ~ 355	H03 ¹¹⁾	Condensation drainage holes
FS 80 ~ 280	H04 ¹²⁾	External earthing
FS 80 ~ 355	H22	IP56 degree of protection (non-heavy-sea)
Modular technology		
FS 80 ~ 355	F70 ¹³⁾	Mounting of separately driven fan
FS 80 ~ 355	F90 ¹⁴⁾	Without external fan and without fan cover
FS 80 ~ 355	F76	Metal fan
FS 112 ~ 355	G04	Mounting of LL 861 900 220 rotary pulse encoder
FS 80 ~ 355	W74	Mounting of Omron encoder (E6B2-CWZ1X-1024) and separated driven fan
FS 112 ~ 355	X05	Prepared for of LL 861 900 220 encoder
FS 80 ~ 355	G46	Prepared for mountings, threaded hole NDE
FS 80 ~ 355	X50	Mounting of Omron rotary pulse encoder (E6B2-CWZ1X-1024) and separately driven fan
Rating plate and test certificates		
FS 80 ~ 355	B02	Acceptance test certificate 3.1 according to EN 10204
FS 80 ~ 355	B07 ¹⁵⁾	Additional rating plate (sticker) for voltage tolerance
Paint finish		
FS 80 ~ 355	S01	Unpainted, only primed
FS 80 ~ 355	S80	Standard finish in RAL 7032
FS 80 ~ 355	S81	Standard finish in RAL 9006
FS 80 ~ 355	W88	Design for TH, W, F1, WF1 and Sea air resistant
Coolant temperature		
FS 80 ~ 355	D03	Coolant temperature -40 to +40 °C
Versions in accordance with standards and specifications		
FS 80 ~ 90	D01 ¹⁶⁾¹⁷⁾	CCC China Compulsory Certification (only for IE3 motors)
FS 80 ~ 355	D34 ¹⁷⁾	China Energy Efficiency Label (only for IE3 motors)
FS 80 ~ 355	D47	TR CU product safety certificate EAC for the Eurasian Customs Union

⁵⁾ Not possible for motors with type of construction IM V5 for FS 315 and above.

⁶⁾ FS 280, FS 315 and FS 355 motor with the regreasing device as standard.

⁷⁾ For horizontal mounting motor, the insulated bearing is located at NDE. For 1LE0021/2 FS250-355 and 1LE0023 FS355 vertical mounting motors, the insulated bearing is located at DE. Not possible for vertical mounting motors 1LE0021/2 FS250-355 and 1LE0023 FS355 combing with option L22.

⁸⁾ Not possible in combination with canopy or separately driven fan (order code: F70).

⁹⁾ Second standard shaft extension on NDE is smaller than DE and provides output at the level of the next smaller frame size.

¹⁰⁾ Only applicable for the types of construction IM V5, IM V1, IM V15 and IM V18. Not possible in combination with option code L05.

¹¹⁾ Only applicable to motor of horizontal mounting.

¹²⁾ FS 315 and FS 355 motor with external earthing as standard.

¹³⁾ When the separately driven fan is mounted, the length of the motor increases by Δl.

¹⁴⁾ Without fan and fan cover, the length of the motor decreases by Δl. By using the power output of rating plate, the motor must have external cooling by air flow. The correct motor cooling is in responsibility of customer. Missing or wrong cooling reduces the lifetime or damages the motor.

¹⁵⁾ Can be ordered only for 230 VΔ/400 VY or 400 VΔ/690 VY (voltage code "22" or "34").

¹⁶⁾ Please add option D34 together with D01. And if this option is selected there will be Chinese characters on the nameplate.

¹⁷⁾ Not possible together with F70, F90, W74, X50 & 60Hz option such as M2A, M2B...

SIMOTICS 1LE0 – Dimensional drawings

IM B3

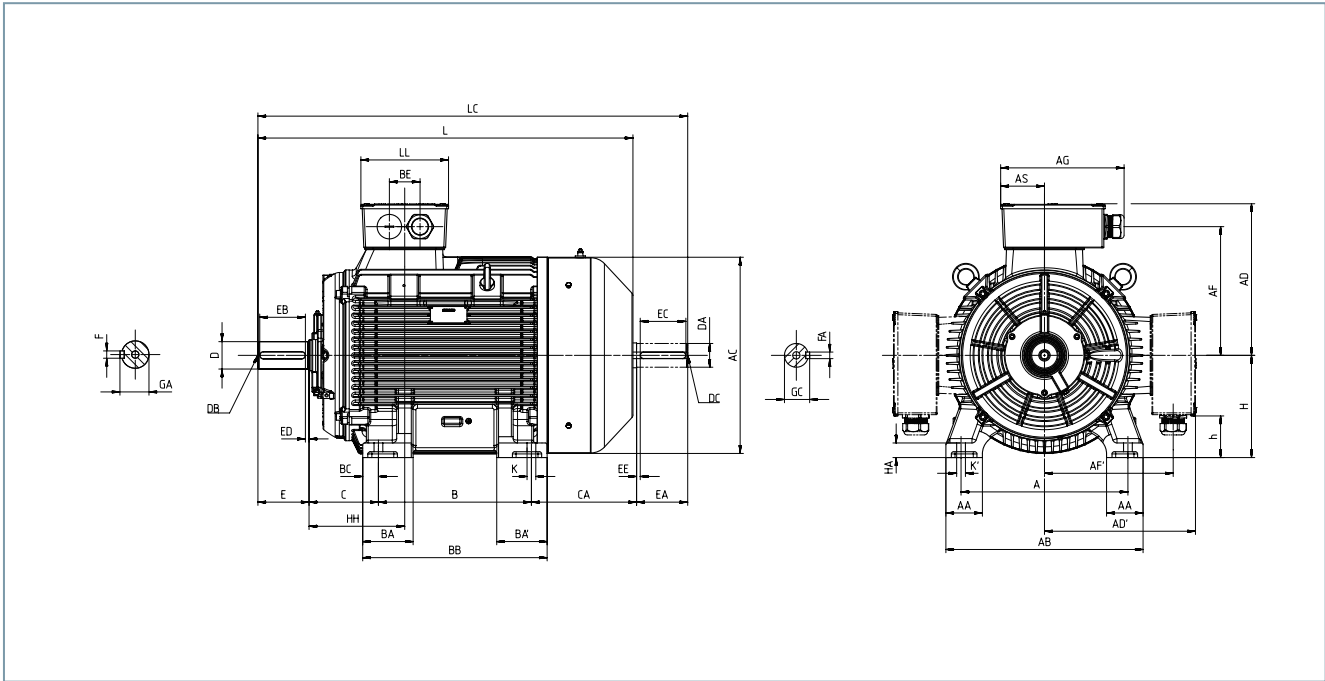

IM B35

For flange dimensions, see Page 59 (Z = the number of retaining holes)

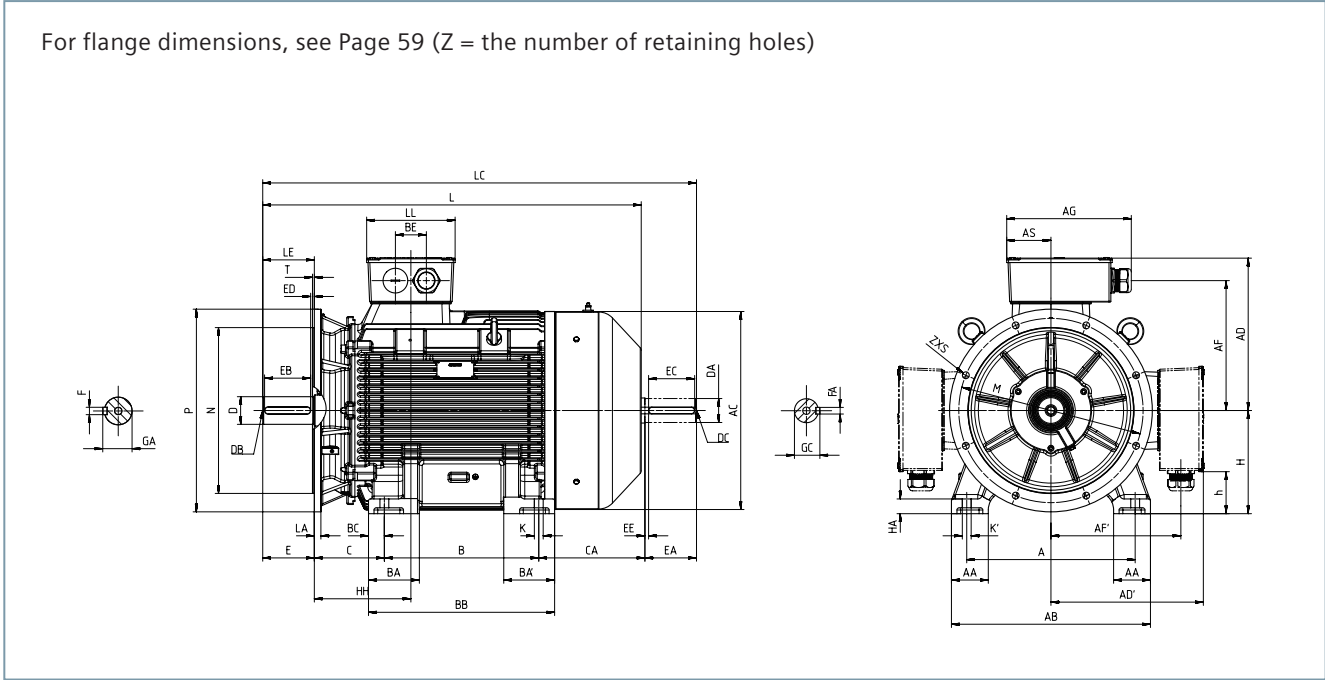

IM B5 and IM V1

For flange dimensions, see Page 59 (Z = the number of retaining holes)

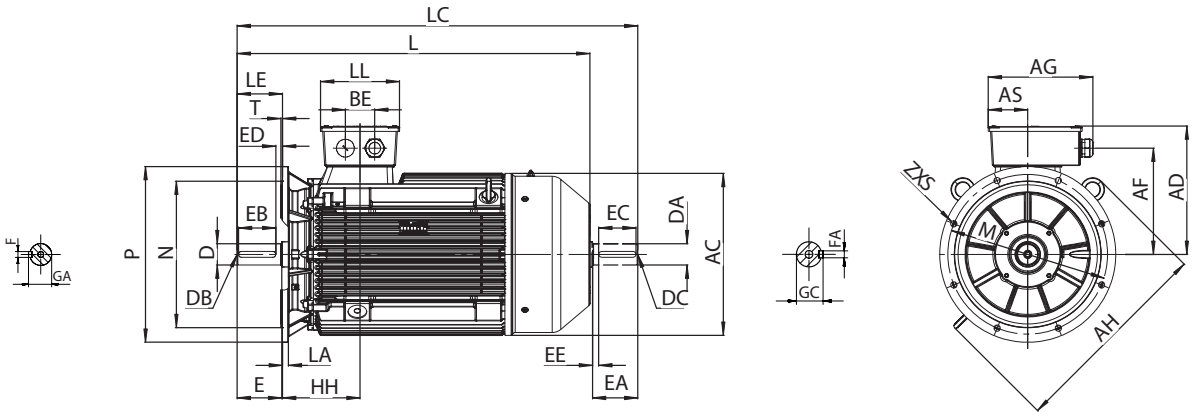

IM B14

For flange dimensions, see Page 59 (Z = the number of retaining holes)

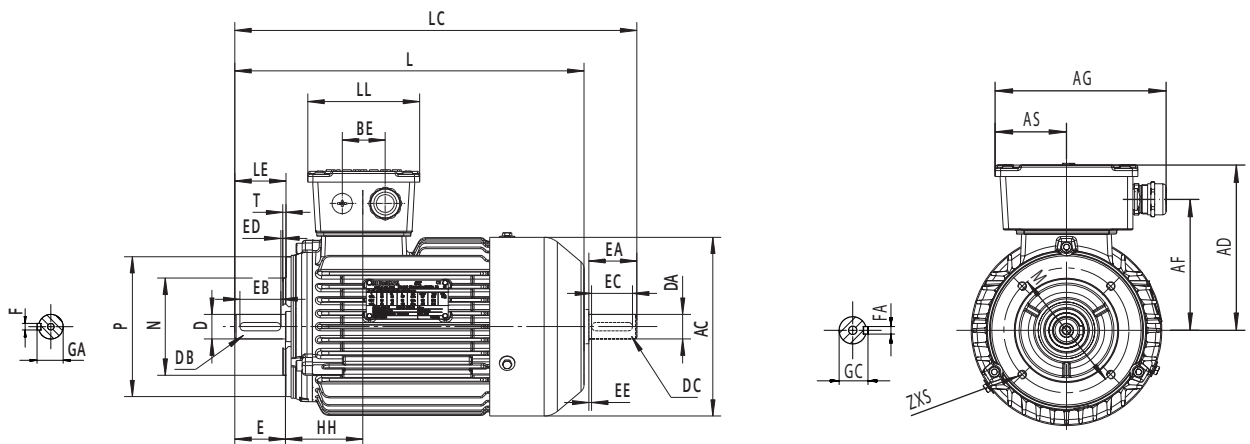

Cast-iron series – 1LE0 – IE1 & IE2

For motor Frame size	Motor type 1LE0-	Num- ber of poles	Dimension designation acc. to IEC																
			A	AA	AB	AC ¹⁾	AD/AD'	AF/AF'	AG	AS	B ²⁾	BA/BA'	BB	BC	BE	C	CA ²⁾	H	HA
80 M	OD.2	2	125	36	160	157	142	110.5	161	65.5	100	44	135	17.5	42	50	103	80	10
		4, 6	125	36	160	157	142	110.5	161	65.5	100	44	135	17.5	42	50	103	80	10
	OD.3	2, 4, 6	125	36	160	157	142	110.5	161	65.5	100	44	135	17.5	42	50	103	80	10
90 S	OE.0	2, 4, 6	140	46	175	175	152	120.5	161	65.5	100	46	140	20	42	56	115	90	10
90 L	OE.4	2, 4, 6	140	46	175	175	152	120.5	161	65.5	125	46	165	20	42	56	115	90	10
100 L	1A.4	2, 4, 6	160	45	200	196	177	140	175	70	140	45	176	18	54	63	133	100	12
	1A.5	4	160	45	200	196	177	140	175	70	140	45	176	18	54	63	133	100	12
112 M	1B.2	2, 4, 6	190	45	226	221	188.5	152	175	70	140	50	180	20	54	70	129.5	112	12
132 S	1C.0	2, 4, 6	216	50	256	259	191.5	175	175	70	140	64	186	23	54	89	178	132	15
		2	216	50	256	259	191.5	175	175	70	140	64	186	23	54	89	178	132	15
132 M	1C.2	4, 6	216	50	256	259	191.5	175	175	70	178	64	224	23	54	89	185	132	15
		6	216	50	256	259	191.5	175	175	70	178	64	224	23	54	89	185	132	15
160 M	1D.2	2, 4, 6	254	60	314	312	255	206	231	94	210	70	258	24	68	108	194	160	20
		2	254	60	314	312	255	206	231	94	210	70	258	24	68	108	194	160	20
160 L	1D.4	2, 4, 6	254	60	314	312	255	206	231	94	254	70	302	24	68	108	210	160	20
180 M	1E.2	2, 4	279	65	339	356	270	221	231	94	241	80	301	30/26 ³⁾	68	121	219	180	20
180 L	1E.4	4, 6	279	65	339	356	270	221	231	94	279	80	339	30/26 ³⁾	68	121	216	180	20
200 L	2A.4	2, 4, 6	318	70	378	397	300	247.5	288	107.5	305	80	369	32/25 ³⁾	85	133	234	200	25
		2, 6	318	70	378	397	300	247.5	288	107.5	305	80	369	32/25 ³⁾	85	133	234	200	25
225 S	2B.0	4	356	80	436	442	327	274	288	107.5	286	80	348	31/25 ³⁾	85	149	255	225	34
225 M	2B.2	2	356	80	436	442	327	274	288	107.5	311	80	373	31/25 ³⁾	85	149	255	225	34
		4, 6																	
250 M	2C.2	2	406	90	490	488	373	310.5	342	123	349	100	421	36/30 ³⁾	84	169	269	250	40
280 S	2D.0	2	457	100	540	538	413	350.5	342	123	368	115	454	43/30 ³⁾	84	190	237	280	40
		4, 6																	
280 M	2D.2	2	457	100	540	538	413	350.5	342	123	419	115	505	43/30 ³⁾	84	190	288	280	40
		4, 6																	
315 S	3A.0	2	508	120	610	608	482	401	401	148	406	165	520	57/35 ³⁾	110	216	351	315	50
315 M	3A.2	2	508	120	610	608	482	401	401	148	457/508	165	668	80/70 ³⁾	110	216	480	315	50
		4, 6																	
315 L	3A.5/3A.6/ 3A.7	2	508	120	610	608	482	401	401	148	457/508	165	668	80/70 ³⁾	110	216	480	315	50
		4																	
355 M	3B.2/3B.3	2	610	116	726	718	655	572	472	198.5	560/630	–	750	68	130	254	536	355	52
		4, 6																	
355 L	3B.4	6	610	116	726	718	655	572	472	198.5	560/630	–	750	68	130	254	536	355	52
		6	610	116	726	718	655	572	472	198.5	560/630	–	750	68	130	254	536	355	52
355 L	3B.5/3B.6	2	610	116	726	718	655	572	472	198.5	560/630	–	750	68	130	254	536	355	52
		4, 6																	

1) Measured across the bolt heads.

2) This dimension is assigned in IEC 60072-1 to the frame size listed.

3) 仅适用于左出线的电机

Cast-iron series – 1LE0 – IE1 & IE2

For motor Frame size	Motor type 1LE0-	Number of poles	Dimension designation acc. to IEC					DE shaft extension						
			HH	K/K'	L	LC	LL	D	DB	E	EB	ED	F	GA
80 M	OD.2	2	76	10	288	323	109	19	M6	40	32	3.5	6	21.5
		4, 6	76	10	288	323	109	19	M6	40	32	3.5	6	21.5
	OD.3	2, 4, 6	76	10	288	323	109	19	M6	40	32	3.5	6	21.5
90 S	OE.0	2, 4, 6	76	10	316	361	109	24	M8	50	40	3.5	8	27
90 L	OE.4		76	10	341	386	109	24	M8	50	40	3.5	8	27
100 L	1A.4	2, 4, 6	93.5	12	390	446	118	28	M10	60	50	3.5	8	31
		4	93.5	12	390	446	118	28	M10	60	50	3.5	8	31
112 M	1B.2	2, 4, 6	92	12	393.5	449.5	118	28	M10	60	50	3.5	8	31
132 S	1C.0	2, 4, 6	121.5	12	480	547	118	38	M12	80	70	4	10	41
		2	121.5	12	480	547	118	38	M12	80	70	4	10	41
132 M	1C.2	4, 6	121.5	12	525	592	118	38	M12	80	70	4	10	41
		6	121.5	12	525	592	118	38	M12	80	70	4	10	41
160 M	1D.2	2, 4, 6	159	15	614	701	158	42	M16	110	100	5	12	45
		2	159	15	614	701	158	42	M16	110	100	5	12	45
160 L	1D.4	2, 4, 6	159	15	674	761	158	42	M16	110	100	5	12	45
180 M	1E.2	2, 4	158	15	683	801	158	48	M16	110	100	5	14	51.5
180 L	1E.4	4, 6	158	15	718	836	158	48	M16	110	100	5	14	51.5
200 L	2A.4	2, 4, 6	202	19	772	892	215	55	M20	110	100	5	16	59
		2, 6	202	19	772	892	215	55	M20	110	100	5	16	59
225 S	2B.0	4	212	19	820	940	215	60	M20	140	125	5	18	64
225 M	2B.2	2	212	19	815	935	215	55	M20	110	100	5	16	59
		4, 6			845	965		60		140	125		18	64
250 M	2C.2	2	260	24	917	1037	246	60	M20	140	125	5	18	64
		4, 6				1067		65					18	69
280 S	2D.0	2	262	24	976	1126	246	65	M20	140	125	5	18	69
		4, 6						75				5	20	79.5
280 M	2D.2	2	262	24	1027	1177	246	65	M20	140	125	5	18	69
		4, 6						75					20	79.5
315 S	3A.0	2	291	28	1113	1265	296	65	M20	140	125	6	18	69
		4, 6			1143	1295		80		170	140		22	85
315 M	3A.2	2	291	28	1293	1445	296	65	M20	140	125	6	18	69
		4, 6			1323	1475		80		170			22	85
315 L	3A.5/3A.6/3A.7	2	291	28	1293	1445	296	65	M20	140	125	6	18	69
		4			1323	1475		80		170	140		22	85
	3A.5/3A.6	6	291	28	1323	1475	296	80	M20	170	140	6	22	85
355 M	3B.2/3B.3	2	298	28	1490	1652	397	75	M20	140	125	6	20	79.5
		4, 6			1520	1712		95	M24	170	140		25	100
	3B.4	6	298	28	1520	1712	397	95	M24	170	140	6	25	100
355 L	3B.5/3B.6	2	298	28	1490	1652	397	75	M20	140	125	6	20	79.5
		4, 6			1520	1712		95	M24	170	140		25	100

Cast-iron series – 1LE0 – IE3

For motor		Dimension designation acc. to IEC														
Frame size	Motor type 1LE0-	Number of poles	A	AA	AB	AC ¹⁾	AD/AD'	AF/AF'	AG	AH	AS	B ²⁾	BA	BA'	BB	BC
80 M	OD.2	2,4	125	36	160	166	145	112	145	-	65.5	100	44	44	135	17.5
	OD.3	2,4,6	125	36	160	166	145	112	145	-	65.5	100	44	44	135	17.5
90 S	OE.0	2,4,6	140	36	175	184	155	120	145	262	65.5	100	46	46	140	20
90 L	OE.4	2,4,6	140	36	175	184	155	120	145	262	65.5	125	46	46	165	20
100 L	1A.4	2,4,6	160	40	200	205	180	142	163	276	69	140	45	45	176	18
	1A.5	4	160	40	200	205	180	142	163	276	69	140	45	45	176	18
112 M	1B.2	2,4,6	190	45	226	230	188.5	152	163	304	69	140	50	50	180	20
132 S	1C.0	2,4,6,8	216	50	256	268	218	177	160	342	69	140	64	64	186	23
	1C.1	2	216	50	256	268	218	177	160	342	69	140	64	64	186	23
132 M	1C.2	4,6,8	216	50	256	268	218	177	160	342	69	178	64	64	224	23
	1C.3	6,8	216	50	256	268	218	177	160	342	69	178	64	64	224	23
160 M	1D.2	2,4,6,8	254	60	314	324	260	208	225	426	94	210	70	70	258	24
	1D.3	2	254	60	314	324	260	208	225	426	94	210	70	70	258	24
160 L	1D.4	2,4,6,8	254	60	314	324	260	208	225	426	94	254	70	70	302	24
180 M	1E.2	2,4	279	65/66 ⁴⁾	339	368	275	223	231	472	94	241	80/53 ⁴⁾	80/87 ⁴⁾	301/328 ⁴⁾	30/26 ⁴⁾
180 L	1E.4	4,6,8	279	65/66 ⁴⁾	339	368	275	223	231	472	94	279	80/53 ⁴⁾	80/87 ⁴⁾	339/328 ⁴⁾	30/26 ⁴⁾
200 L	2A.4	2,4,6	318	70	378	410	305	250	288	540	107.5	305	80/65 ⁴⁾	80/65 ⁴⁾	369/355 ⁴⁾	32/25 ⁴⁾
	2A.5	2,6,8	318	70	378	410	305	250	288	540	107.5	305	80/65 ⁴⁾	80/65 ⁴⁾	369/355 ⁴⁾	32/25 ⁴⁾
225 S	2B.0	4	356	80	436	449	330	278	288	564	107.5	286	90/60 ⁴⁾	90/85 ⁴⁾	348/361 ⁴⁾	31/25 ⁴⁾
225 M	2B.2	2	356	80	436	449	330	278	288	564	107.5	311	90/60 ⁴⁾	90/85 ⁴⁾	373/361 ⁴⁾	31/25 ⁴⁾
		4,6,8														
250 M	2C.2	2 4,6,8	406	90/100 ⁴⁾	490/496 ⁴⁾	503	373	310.5	342	610	123	349	100/97 ⁴⁾	100/97 ⁴⁾	421/409 ⁴⁾	36/30 ⁴⁾
280 S	2D.0	2 4,6,8	457	100	540	540	420	352.5	338	682	120	368	138/75 ⁴⁾	138/126 ⁴⁾	454/479 ⁴⁾	43/30 ⁴⁾
280 M	2D.2	2 4,6,8	457	100	540	540	420	352.5	338	682	120	419	138/75 ⁴⁾	138/126 ⁴⁾	505/479 ⁴⁾	43/30 ⁴⁾
315 S	3A.0	2	508	120	610	623	485	399	401	805	148	406/457	140/200 ⁴⁾	190/200 ⁴⁾	571	57
		4,6,8										406	140/200 ⁴⁾	140/200 ⁴⁾	510	
315 M	3A.2	2 4,6,8	508	120	610	623	485	399	401	805	148	406/457	140/200 ⁴⁾	190/200 ⁴⁾	571	57
315 L	3A.5/3A.6/ 3A.7	2 4,6,8	508	120	610	623	485	399	401	805	148	508	140/200 ⁴⁾	140/251 ⁴⁾	622	57
355 M	3B.2	2	610	120	730	712	650	542	464	935	173.5	560	153	153	696	68
		4,6,8														
		2	610	120	730	712	650	542	464	935	173.5	560	153	153	696	68
	3B.3	2 4,6,8	610	120	730	712	650	542	464	935	173.5	560	153	153	696	68
	3B.4	6	610	120	730	712	650	542	464	935	173.5	560	153	153	696	68
355 L	3B.5	2	610	120	730	712	650	542	464	935	173.5	630	153	207	750	68
		4,6,8														
	3B.6	2 4,6,8	610	120	730	712	650	542	464	935	173.5	630	153	207	750	68

1) 包含螺栓头的尺寸

2) 该尺寸为DIN EN 50347标准所列机座号对应尺寸

3) 仅适用于配置H08选件的电机

4) 仅适用于左出线的电机

Cast-iron series – 1LE0 – IE3

For motor			Dimension designation acc. to IEC																
Frame size	Motor type 1LE0-	Number of poles	BE	C	CA ²⁾	H	HA	HH	K/K'	L	LC	LL	D	DB	E	EB	ED	F	GA
80 M	OD.2	2,4	42	50/90 ³⁾	143	80	10	76	10	335	363	109	19	M6	40	32	4	6	21.5
	OD.3	2,4,6	42	50/90 ³⁾	143	80	10	76	10	335	363	109	19	M6	40	32	4	6	21.5
90 S	OE.0	2,4,6	42	56/106 ³⁾	140	90	10	76	10	370	411	109	24	M8	50	40	5	8	27
90 L	OE.4	2,4,6	42	56/106 ³⁾	165	90	10	76	10	395	436	109	24	M8	50	40	5	8	27
100 L	1A.4	2,4,6	54	63/148 ³⁾	203.5	100	12	93.5	12	465	516.5	116	28	M10	60	50	5	8	31
	1A.5	4	54	63/148 ³⁾	203.5	100	12	93.5	12	465	516.5	116	28	M10	60	50	5	8	31
112 M	1B.2	2,4,6	54	70/125 ³⁾	182	112	15	92	12	455	504.5	118	28	M10	60	50	5	8	31
132 S	1C.0	2,4,6,8	54	89/139 ³⁾	203	132	15	121.5	12	510	572	116	38	M12	80	70	5	10	41
	1C.1	2	54	89/139 ³⁾	203	132	15	121.5	12	510	572	116	38	M12	80	70	5	10	41
132 M	1C.2	4,6,8	54	89/146 ³⁾	220	132	15	121.5	12	565	627	116	38	M12	80	70	5	10	41
	1C.3	6,8	54	89/146 ³⁾	220	132	15	121.5	12	565	627	116	38	M12	80	70	5	10	41
160 M	1D.2	2,4,6,8	68	108/112 ³⁾	193	160	20	159	15	620	701	158	42	M16	110	100	5	12	45
	1D.3	2	68	108/112 ³⁾	193	160	20	159	15	620	701	158	42	M16	110	100	5	12	45
160 L	1D.4	2,4,6,8	68	108/108 ³⁾	190	160	20	159	15	660	742	158	42	M16	110	100	5	12	45
180 M	1E.2	2,4	68	121/124 ³⁾	228	180	22/20 ⁴⁾	158	15	695	815	158	48	M16	110	100	5	14	51.5
180 L	1E.4	4,6,8	68	121/112 ³⁾	216	180	22/20 ⁴⁾	158	15	725	840	158	48	M16	110	100	5	14	51.5
200 L	2A.4	2,4,6	85	133/138 ³⁾	249	200	25	203	19	790	907	215	55	M20	110	100	5	16	59
	2A.5	2,6,8	85	133/138 ³⁾	249	200	25	203	19	790	907	215	55	M20	110	100	5	16	59
225 S	2B.0	4	85	149/136 ³⁾	255	225	34	212	19	825	940	215	60	M20	140	125	10	18	64
225 M	2B.2	2	85	149/166 ³⁾	285	225	34	212	19	850	965	215	55	M20	110	100	5	16	59
		4,6,8		285						880	995	60		140	125	10	18	64	
250 M	2C.2	2	84	168/158 ³⁾	270	250	40/44 ⁴⁾	260	24	915	1037	246	60	M20	140	125	10	18	64
		4,6,8									1067	65							69
280 S	2D.0	2	84	190/172 ³⁾	288	280	40	262	24	980	1126	240	65	M20	140	125	10	18	69
		4,6,8										75					10	20	79.5
280 M	2D.2	2	84	190/172 ³⁾	288	280	40	262	24	1030	1177	240	65	M20	140	125	10	18	69
		4,6,8										75						20	79.5
315 S	3A.0	2	110	216/260 ³⁾	443	315	50	291	28	1200	1345	296	65	M20	140	125	10	18	69
		4,6,8		216/170 ³⁾	353					1140	1285	80		170	140	25	22	85	
315 M	3A.2	2	110	216/209 ³⁾	392	315	50	291	28	1200	1345	296	65	M20	140	125	10	18	69
315 L	3A.5/3A.6/ 3A.7	2	110	216/278 ³⁾	461	315	50	291	28	1320	1465	296	65	M20	140	125	10	18	69
		4,6,8								1350	1495	80		170	140	25	22	85	
355 M	3B.2	2	130	254/258 ³⁾	428	355	53	281	28	1370	1522	347	75	M20	140	125	10	20	79.5
		4,6,8								1400	1582	95	M24	170	140	25	25	100	
		2	130	254/258 ³⁾	428	355	53	281	28	1370	1522	347	75	M20	140	125	10	20	79.5
355 L	3B.5	2	130	254/258 ³⁾	428	355	53	281	28	1400	1582	347	95	M24	170	140	25	25	100
		4,6,8								1400	1582	95	M24	170	140	25	25	100	
		6	130	254/258 ³⁾	428	355	53	281	28	1400	1582	347	95	M24	170	140	25	25	100
355 L	3B.6	2	130	254/308 ³⁾	478	355	53	281	28	1490	1642	347	75	M20	140	125	10	20	79.5
		4,6,8								1520	1702	95	M24	170	140	25	25	100	
		2	130	254/308 ³⁾	478	355	53	281	28	1490	1642	347	75	M20	140	125	10	20	79.5
		4,6,8							1520	1702	95	M24	170	140	25	25	100		

1) 包含螺栓头的尺寸

2) 该尺寸为DIN EN 50347标准所列机座号对应尺寸

3) 仅适用于配置H08选件的电机

4) 仅适用于左出线的电机

SIMOTICS 1LE0 – Flange dimensions

Type of construction – IM B5

Type of construction – IM B14

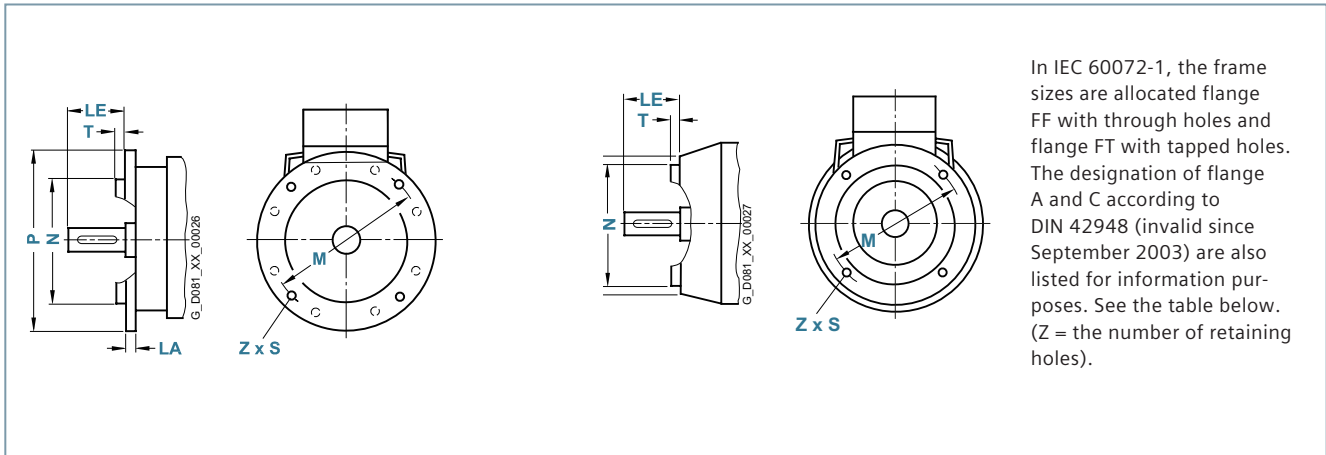

In IEC 60072-1, the frame sizes are allocated flange FF with through holes and flange FT with tapped holes. The designation of flange A and C according to DIN 42948 (invalid since September 2003) are also listed for information purposes. See the table below. (Z = the number of retaining holes).

Frame size	Type of construction	Flange type	Flange with through holes (FF/A) / tapped holes (FT/C)		Dimension designation acc. to IEC							
			Acc. to IEC 60072-1	Acc. to DIN 42948	LA	LE	M	N	P	S	T	Z
Cast-iron series – 1LE0												
80	IM B5, IM B35, IM V1, IM V3	Flange	FF165	A 200	10	40	165	130	200	12	3.5	4
	IM B14, IM V18, IM V19	Standard flange	FT100	C 120	–	40	100	80	120	M6	3	4
90	IM B5, IM B35, IM V1, IM V3	Flange	FF165	A 200	10	50	165	130	200	12	3.5	4
	IM B14, IM V18, IM V19	Standard flange	FT115	C 140	–	50	115	95	140	M8	3	4
100	IM B5, IM B35, IM V1, IM V3	Flange	FF215	A 250	11	60	215	180	250	14.5	4	4
	IM B14, IM V18, IM V19	Standard flange	FT130	C 160	–	60	130	110	160	M8	3.5	4
112	IM B5, IM B35, IM V1, IM V3	Flange	FF215	A 250	11	60	215	180	250	14.5	4	4
	IM B14, IM V18, IM V19	Standard flange	FT130	C 160	–	60	130	110	160	M8	3.5	4
132	IM B5, IM B35, IM V1, IM V3	Flange	FF265	A 300	12	80	265	230	300	14.5	4	4
	IM B14, IM V18, IM V19	Standard flange	FT165	C 200	–	80	165	130	200	M10	3.5	4
160	IM B5, IM B35, IM V1, IM V3	Flange	FF300	A 350	13	110	300	250	350	18.5	5	4
	IM B14, IM V18, IM V19	Standard flange	FT215	C 250	–	110	215	180	250	M12	4	4
180	IM B5, IM B35, IM V1, IM V3	Flange	FF300	A 350	15	110	300	250	350	18.5	5	4
200	IM B5, IM B35, IM V1, IM V3	Flange	FF350	A 400	17	110	350	300	400	18.5	5	4
225	IM B5, IM B35, IM V1, IM V3	Flange	FF400	A 450	20	110/140	400	350	450	18.5	5	8
250	IM B5, IM B35, IM V1, IM V3	Flange	FF500	A 550	22	140	500	450	550	18.5	5	8
280	IM B5, IM B35, IM V1, IM V3	Flange	FF500	A 550	22	140	500	450	550	18.5	5	8
315	IM B5, IM B35, IM V1, IM V3	Flange	FF600	A 660	22	140/170	600	550	660	24	6	8
355	IM B5, IM B35, IM V1, IM V3	Flange	FF740	A 800	22	140/170	740	680	800	24	6	8

**Published by
Siemens AG 2021**

Digital Industries
Motion Control
P.O. Box 31 80
91050 Erlangen
Germany

Subject to change without prior notice
DIMC-B80018-00-76CN
Printed in China

The information provided in this brochure contains merely general descriptions or characteristics of performance which in case of actual use do not always apply as described or which may change as a result of further development of the products. An obligation to provide the respective characteristics shall only exist if expressly agreed in the terms of contract.

All product designations may be trademarks or product names of Siemens AG or supplier companies whose use by third parties for their own purposes could violate the rights of the owners.